

# Ham Radio from Indoors

Steve Ford, WB8IMY

## No Outdoor Antennas Required!

- Low Power and Digital Modes
- Antennas for Indoors
- Interference and Safety Tips



**ARRL** The national association for  
AMATEUR RADIO®

# Ham Radio from **Indoors**

Steve Ford, WB8IMY

## No Outdoor Antennas Required!

- Low Power and Digital Modes
- Antennas for Indoors
- Interference and Safety Tips



**ARRL** The national association for  
**AMATEUR RADIO®**  
[www.arrl.org](http://www.arrl.org)

## Cover Photos —

**Background:** An attic antenna installation at the home of Brad Bylund, WA6MM.

**Foreground, center:** A West Mountain Radio Rigblaster Advantage digital interface; **right,** a Comet CAA500 Mark II antenna analyzer; **bottom,** a Rig Expert T17 digital interface.

Copyright © 2017 by

The American Radio Relay League, Inc.

*Copyright secured under the Pan-American Convention*

All rights reserved. No part of this work may be reproduced in any form except by written permission of the publisher. All rights of translation are reserved.

Printed in USA

*Quedan reservados todos los derechos*

ISBN: 978-1-62595-067-3

First Edition

eBooks created by [www.ebookconversion.com](http://www.ebookconversion.com)

# CONTENTS

## **1 The Indoor Challenge**

Learn how to make the most of indoor operating with CW and digital modes.

## **2 Indoor Antenna Design**

From loops to dipoles, there is an indoor antenna that's guaranteed to work for you.

## **3 Dealing with Interference**

When operating indoors, you're likely to be plagued with interference from your neighbors, and you may cause some interference yourself. This chapter offers concrete solutions.

## **4 RF Safety**

You and your neighbors will be living in proximity to the RF you'll generate. There is no danger, but it never hurts to be cautious.

# The Indoor Challenge

You'd be surprised at how many amateurs operate stations that are entirely indoors. By "entirely indoors," I mean stations that exist completely within the confines of the homes in which the operators live. Some hams can install semi-invisible antennas outdoors by cleverly hiding wires along exterior walls, or by exploiting the classic ruse of using rain gutters as antennas, but this book is devoted to those who lack even that luxury. When I say "HF indoors," I mean that *everything* is indoors – including the antenna system.

Most amateurs don't operate indoor stations by choice. They know that, at HF frequencies, outside antennas are almost always superior to indoor antennas. Even so, thanks to restrictions imposed by their homeowner associations or landlords, they have no other options. They are forced to enjoy Amateur Radio as best they can by sharing their living quarters with their antennas.

Without question, indoor operating on the HF bands presents serious challenges, but these challenges can be overcome. No, you won't have the strongest signals on the bands and, no, you won't be able to pull those weak DX stations out of the noise.

But...

You can enjoy the pleasures of Amateur Radio to a degree that you may not have thought possible. I'm living proof. At the time of this writing, I have been licensed for 45 years and I have spent a significant portion of that time operating indoors. Between years spent in college and more years climbing the corporate ladder, I usually found myself living in apartments or condominiums. My HF antennas were sometimes hidden in attics, but more often they graced the walls of my living rooms or bedrooms.

Some of my apartment homes were ground-floor units, so my antennas had effective altitudes of only 7 or 8 feet. Occasionally, I was fortunate to live in a third or fourth story apartment, and the performance difference was quite noticeable.



**Jeff Blaine, AC0C, earned awards and operated successfully in contests with a station that was entirely indoors. This is a glimpse of a multiband wire antenna he added to his attic.**

Despite such sub-optimal trappings, however, I still made many enjoyable contacts and even managed to snag my Worked All States award and a DX Century Club award – all with antennas that never saw the light of day.

If you're willing to calibrate your expectations, coming to terms with the fact that contacts won't always be easy, indoor operating on the HF bands can be a rewarding experience.

## **Optimize Your Operating**

Before we delve into antenna ideas in the next chapter, I want to spend some time discussing the issue of operating *modes*. Single sideband (SSB), for example, is the most popular HF voice mode. An on/off keyed Continuous Wave (CW) signal is often characterized as the original digital mode, and it remains widely used today. Then you have all the modern digital communications modes from PSK31 to JT65 and everything in between.

One important characteristic of any operating mode is the *bandwidth* its signal occupies. SSB spreads your transmit energy over a little less than 3 kHz of RF spectrum. In contrast, a CW signal may be only 50 Hz wide while a PSK31 signal is also quite narrow at about 62 Hz.

So why does signal bandwidth matter?

Without going off the technical deep end, imagine a garden hose with an adjustable nozzle. If you set the nozzle for FINE SPRAY, the water is diffused into a wide cone of droplets. The droplets will strike the ground at your feet, and the ground will certainly become wet, but each square inch of soil will receive relatively little water overall and the droplets will land with little energy.

However, if you switch the nozzle to JET, all the water in the hose is suddenly focused into a narrow stream. The water strikes the ground with considerable force, perhaps enough to actually start ripping away the soil. A high-pressure cleaner works in exactly this way.

With the water analogy in mind, generating an SSB signal is somewhat like setting the nozzle to FINE SPRAY. You're spreading your precious RF energy over a wide slice of spectrum and the receiving station will have to capture a fair amount of it to understand what you are saying.

But if you switch to a mode such as CW, you're effectively setting the nozzle to JET. Now your RF energy is concentrated within a much narrower bandwidth. The receiving station doesn't have to capture nearly as much of your signal to decode the Morse code you are sending.

Hams with outdoor antennas can compensate for the diffused power of an SSB signal by using directional antennas that act somewhat like magnifying glasses to focus energy. (RF radiation is just a different frequency of light, after all!) They can also transmit at high power levels, up to 1.5 kW, depending on the frequencies and their license privileges. High RF power and a directional antenna is a potent combination!

But as an indoor operator, you are denied these advantages. You don't have room for an HF directional antenna, and it isn't safe to generate 1.5 kW in an indoor environment (we'll discuss RF safety in a later chapter).

When you are restricted to low power (less than 100 W) and rather poor antennas, you need to compensate by using modes that either concentrate your RF energy, or use digital encoding and processing, or both. This is not to say that you can't operate SSB from an indoor station. However, chances are good that you'll find it frustrating. In my experience, success was not common unless the other station had an optimized directional antenna and was willing to use all of his transceiver's signal enhancement tools to make my voice intelligible.

On the other hand, I was able to routinely make contacts throughout North America with just 5 W of CW applied to some truly awful antennas. This type of low-power operating, known as *QRP*, is extremely popular among indoor amateurs. There is nothing magical about QRP. In truth, your success with QRP depends in large part on the other guy's station and his ability to pull your signal out of the noise. The good news is there are plenty of higher profile stations available to contact. The other great thing about QRP is that it usually doesn't wreak havoc with your neighbor's consumer electronic devices. We'll discuss that issue later in the book.

## **CW – Even If You Don't “Do” CW**

If you are already a CW operator and you're comfortable banging out Morse on a straight key or a set of paddles, this section isn't for you. Skip ahead to the discussion of digital modes, which you may find interesting!

If you're still reading this sentence, it is safe to say that you probably aren't a proficient CW operator. Becoming proficient takes time and practice; it's something I'd encourage for anyone looking to add another skill to their Amateur Radio resume.

But for now, let's assume that you really have no particular desire to become proficient – at least not at this time. If that is the case, I have good news: you can send and receive CW with *software*. All you need, in addition to the software, of course, is a computer and an interface to key your transceiver.

See **Figure 1.1** for a simplified diagram of typical station setups for operating with a computer. You'll note that with one exception, all the configurations include an interface. A so-called *multimode interface* does more than CW, though. This device will allow you to send and receive CW in addition to a wide variety of digital modes, which we'll discuss in the next section. When shopping for a multimode interface, however, make sure that it includes CW keying; some interfaces do not. For example, at the time this book was published, the following interfaces offered CW keying...

The Rigblaster  
Advantage  
interface by West  
Mountain Radio.





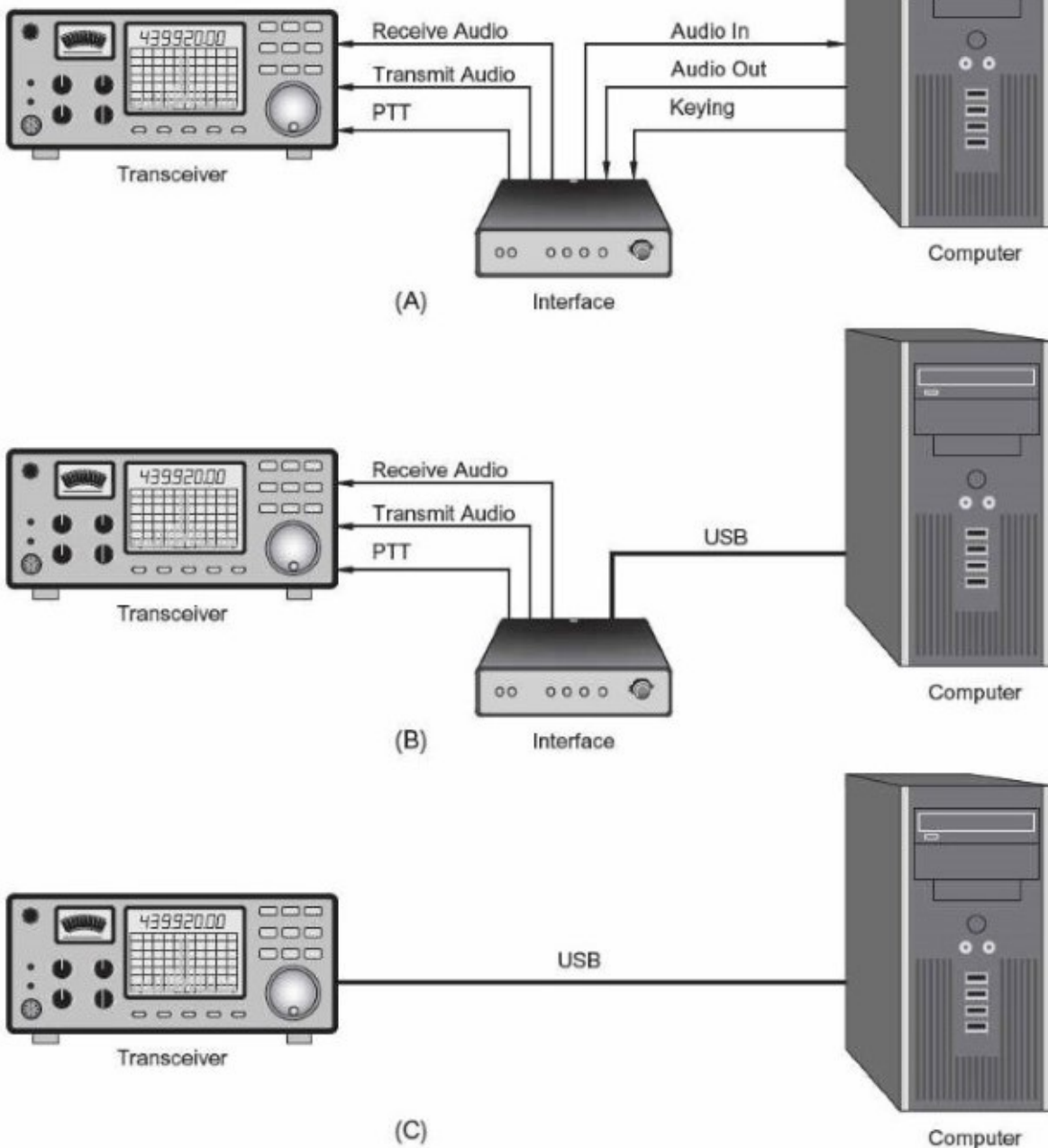

Figure 1.1 – Three of the most common configurations for interfacing your transceiver with your computer. (A) The most common setup for many years was based on an interface that took transmit and receive audio from the computer's sound card, along with transmit/receive keying from one of the computer's COM ports, and passed everything to the transceiver in a way that kept the signal lines isolated. This type of interface is increasingly uncommon. (B) Many interfaces available at the time this book was written are USB devices. A single USB cable plugs into the computer. Not only is the computer's sound card not used, the interface contains its own sound device. In turn, the interface supplies transmit audio to the radio, processes receive audio from the radio and handles transmit/receive keying. (C) The future will likely see the disappearance of the interface entirely as transceivers incorporate their own computer interfacing. Today, a number of moderate to higher-priced rigs have added this feature.

- West Mountain Radio RigBlaster Advantage; [www.westmountainradio.com](http://www.westmountainradio.com)
- MFJ Enterprises MFJ-1275; [www.mfjenterprises.com](http://www.mfjenterprises.com)
- RigExpert TI-7; [www.rigexpert.com](http://www.rigexpert.com)

And no doubt a Google search will turn up several more.

If you have no interest in digital operating, consider just a simple CW-only interface. The USB device shown in **Figure 1.2** takes the CW keying pulses generated by your software and translates them to on/off keying at a jack that you can plug into your transceiver. Devices like these are commonly available on eBay and elsewhere, typically for less than \$20. As you will see later in this chapter, this type of USB keying is accomplished by creating a *virtual COM port* in your computer. Once you determine the number of this COM port (COM 4, for example), you can enter that number into your CW software menu, and it will use the port to key your radio. Finding the COM port in *Windows* is a matter of going into Device Manager and looking up “Ports.” We’ll discuss this in more detail later.



**Figure 1.2** – This is an example of a simple CW-only interface available from eBay and other sources. These typically sell for less than \$20.

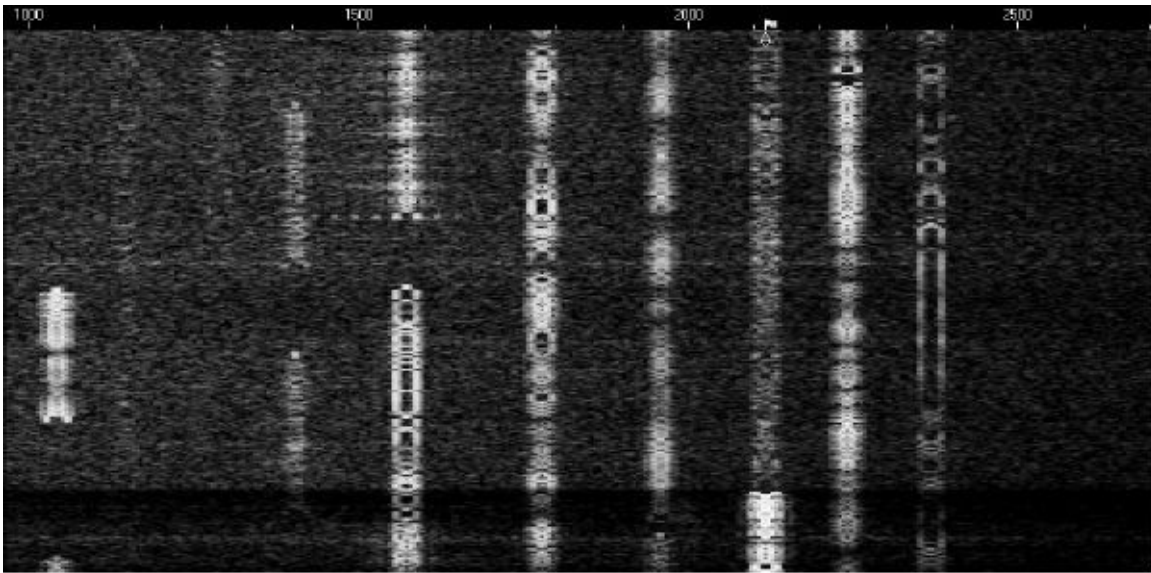

Figure 1.3 – A PSK31 waterfall display. Each line represents a PSK31 signal.

When it comes to software, there are many programs available and quite a few of them are free. *Fldigi*, for example, is a free multimode application for *Windows*, *OS X* and *Linux* that will not only send and receive CW, it will send and receive dozens of digital modes. You'll find it at [www.w1hkj.com](http://www.w1hkj.com).



MFJ's 1275 digital interface.



The RigExpert TI-7 interface.



## Receiving CW with *Fldigi*, multimode digital software for *Windows*, *OS X* and *Linux*.

If you are only interested in CW, you will find CW-only software such as *CW Decoder* by WD6CNF at [www.hotamateurprograms.com](http://www.hotamateurprograms.com). Despite the name, *CW Decoder* will also send brief “canned” CW messages. Once again, a little time spent with Google will turn up more applications. For *Windows*, also take a look at *CWGet*, a Morse code receive-only application at [www.dxsoft.com/en/products/cwget/](http://www.dxsoft.com/en/products/cwget/), and its Morse sending companion, *CWType* at [www.dxsoft.com/en/products/cwtype/](http://www.dxsoft.com/en/products/cwtype/).

If you are a smartphone or tablet user, you may want to investigate the Morse decoders available for both Apple and Android devices. All you have to do is place your tablet or smartphone close to your transceiver speaker, and the app will translate Morse into English text.

CW sending software generally works well, especially if you are a decent typist. With the software in the transmit mode, whatever you type on your keyboard is instantly translated to clean CW keying pulses and applied to your radio.

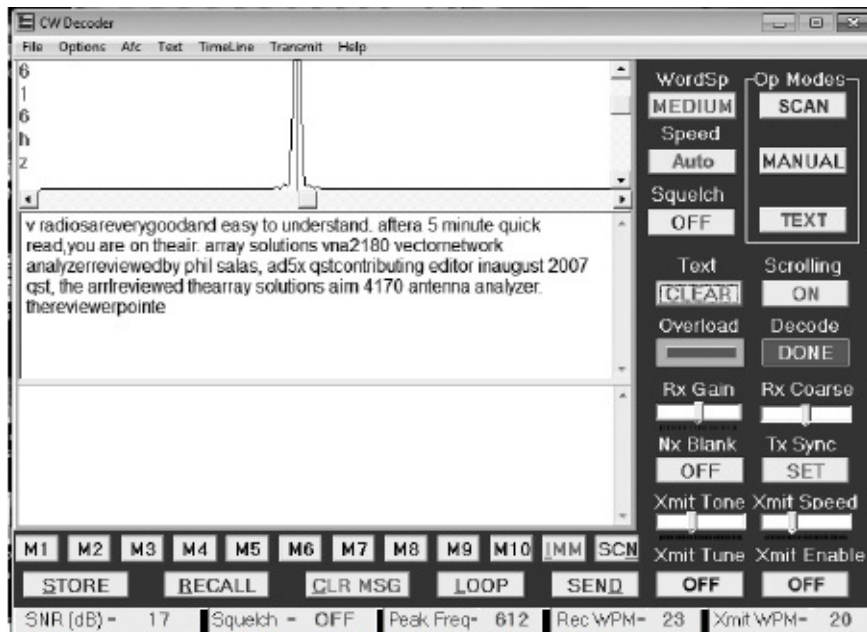

**CW Decoder by WD6CNF will receive CW and can transmit CW macro messages.**

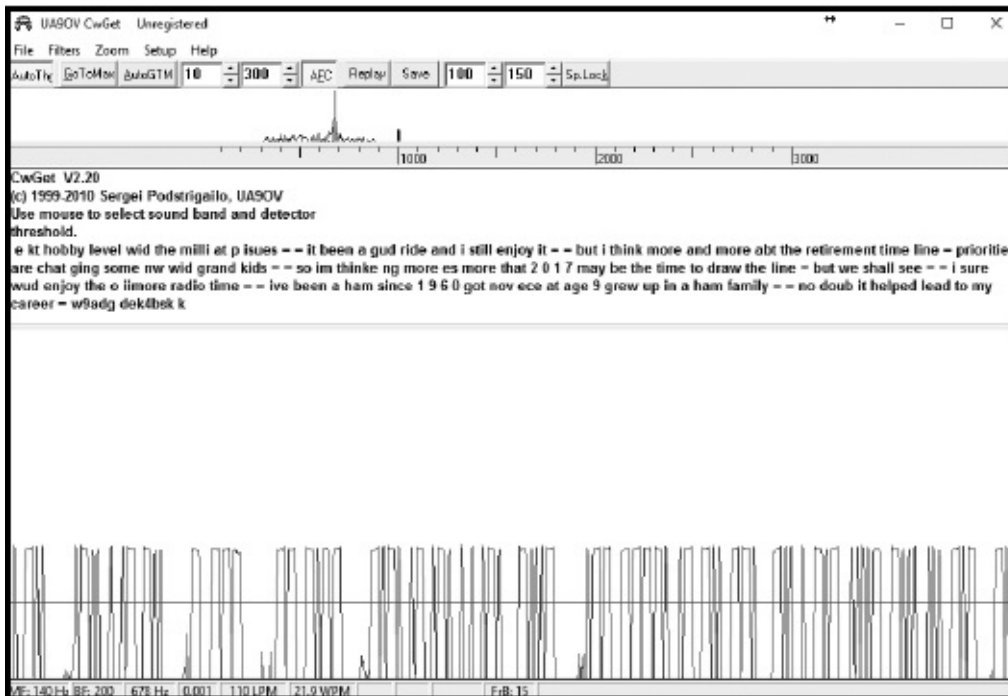

**CWGet, by Sergei Podstrigailo, UA9OV, is a popular CW receiving program for Windows.**

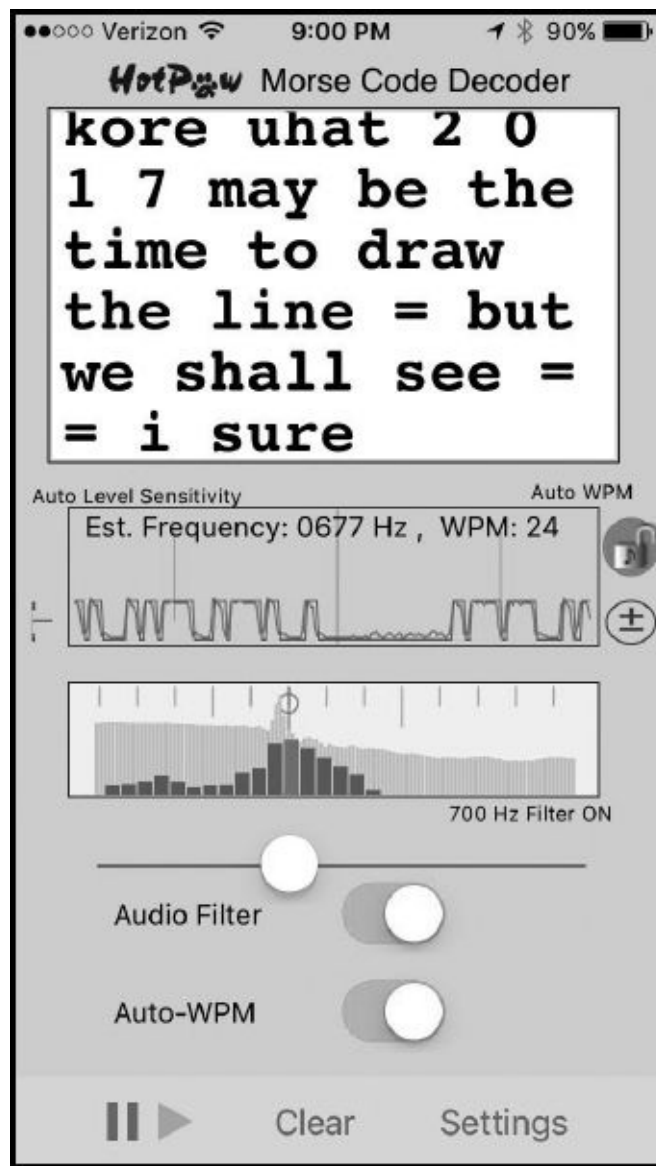

**The *MorseDecoder* app available on Apple iTunes can be used to decode Morse with your iPhone or iPad. Similar apps exist for Android devices.**

CW reception, however, is another matter. Clever as some applications may be, I've yet to see software that can beat the human brain when it comes to decoding CW. If the CW signal you are receiving is strong and not plagued with interference, and if the operator at the other end is proficient with his sending (or if he is using a computer like you), your software will be able to decode with a high degree of accuracy. But if the operator is a little sloppy, or if conditions are marginal, all bets are off. CW that might be perfectly understandable to even a novice operator can become gibberish on your computer monitor.

In my experience, CW decoding software is best used when you are hunting for quick contacts rather than lengthy conversations. Since you can't trust the software to precisely decode everything, a casual conversation can be problematic, largely because you don't really know what the other person is about to send.

During a contest, on the other hand, you generally know what the other station is going to send. If you are using the "search and pounce" technique, you have the luxury of listening to

the target station as the operator sends the contest exchange, such as “599 Ohio,” repeatedly to others. When you’re confident you’ve copied everything correctly, it’s your turn to jump in. You already know what he is going to send, so even if band conditions suddenly deteriorate and you can only grasp fragments, those fragments will usually suffice.

The same is true when hunting DX. Most DX stations are only interested in exchanging the basic information necessary for a valid contact: your call sign and a signal report (almost always “599”). Most amateurs can recognize the sounds of their own call signs in Morse code, even at high speeds. So, you keep hammering away at the DX station when she is listening, sending your call sign over and over until she finally picks your signal out of the pileup.

ME: WB8IMY

DX: WB8IMY 5NN (meaning “599”)

ME: 5NN TU (TU means “thank you”)

DX: TU VK0IR UP 5 (Translation: Thank you. VK0IR listening up 5 kHz)

Another interesting phenomenon that many have noticed is that time spent watching the decoder while simultaneously listening to signals can improve your ability to copy. Over a period of weeks and months, the ability to decode Morse by ear gradually sinks in.

## The Digital Alternative

Let’s say CW just isn’t your game, no matter how it’s done. Fear not; you have alternatives in the digital universe that are every bit as effective for indoor operating as CW, if not more so. A basic HF digital station consists of little more than an SSB transceiver, a computer, and an interface device – such as one of those we discussed earlier, or an interface you build yourself. (See the sidebar, “Build the G4ILO Interface.”) Depending on the type of transceiver you own, it may already have the computer interface built in. In that case, all you need is the computer.

A complete explanation of HF digital operating is way beyond the scope of this book because there are so many different modes in use (about 60 at last count). For instance, there is radio teletype or *RTTY*, an old digital mode that is still popular for contesting and DXing. You’ll also hear about JT65, a highly effective mode for hunting contacts for awards such as DX Century Club or Worked All States, especially with low power.

If you want a detailed overview of digital operating, I recommend the following books: *Get On the Air with HF Digital* and *Work the World with JT65 and JT9*. Both are available from the ARRL online store at [www.arrl.org/shop](http://www.arrl.org/shop). But to keep things as simple as possible – and to give you a taste of what digital operating is like – let me introduce you to the most popular HF digital mode in use at the time this book was written, one that is excellent for low-power operating: *PSK31*.

### The PSK31 Nitty Gritty

The “PSK” in PSK31 stands for Phase Shift Keying, the modulation method that is used to generate the signal; “31” is the bit rate. Technically speaking, the bit rate is really 31.25, but

“PSK31.25” isn’t nearly as catchy.

Think of Morse code for a moment. It is a simple binary code expressed by short signal pulses (dits) and longer signal pulses (dahs). By combining strings of dits and dahs, we can communicate the entire English alphabet along with numbers and punctuation. Morse uses gaps of specific lengths to separate individual characters and words. Even beginners quickly learn to recognize these gaps; they don’t need special signals to tell them that one character or word has ended and another is about to begin.

## Build the G4ILO Interface

In **Figure A**, you’ll find the schematic diagram and parts list for an inexpensive interface you can build yourself. I didn’t include this interface in our discussion about sending Morse code with a computer because it does not work well for that application. Instead, this interface is intended for all of the other “sound-card” based digital modes such as PSK31, JT65, RTTY and many more.

This interface was designed by the late Julian Moss, G4ILO, and it uses an inexpensive USB sound device that you’ll find on sites, such as Amazon, for less than \$10. Just go to [www.amazon.com](http://www.amazon.com) and search for “external sound adapter.” Not counting the cost of the enclosure, you can build Julian’s interface for less than \$25.

Julian’s design requires that you pry open the sound adapter and use a Volt-Ohm Meter to locate a place to tap the 5 V dc supply and ground. This allows the interface to be powered from the host computer. The alternative is to supply 5 V dc from another source. As you’ll see in **Figure A**, Julian connects the headphone output of the adapter to a VOX (Voice Operated Switch) circuit that keys your transceiver PTT (push-to-talk) whenever it detects transmit audio from your computer and the digital software you happen to be using. In addition, the circuit also taps the headphone audio to feed to the transceiver as transmit audio, with a 1 k $\Omega$  potentiometer (R2) to control the level.

For receiving, the transceiver’s receive audio – obtained either from a rear panel accessory port or an external speaker/headphone jack – is fed directly to the adapter’s microphone input.

The interface attached to your computer with a female-to-male USB extension cable that you can also pick up from Amazon and many other vendors for less than \$10. When you attach the interface, your computer should recognize it as a separate sound device. In your digital software, you’ll need to select the device for your transmit and receive audio.



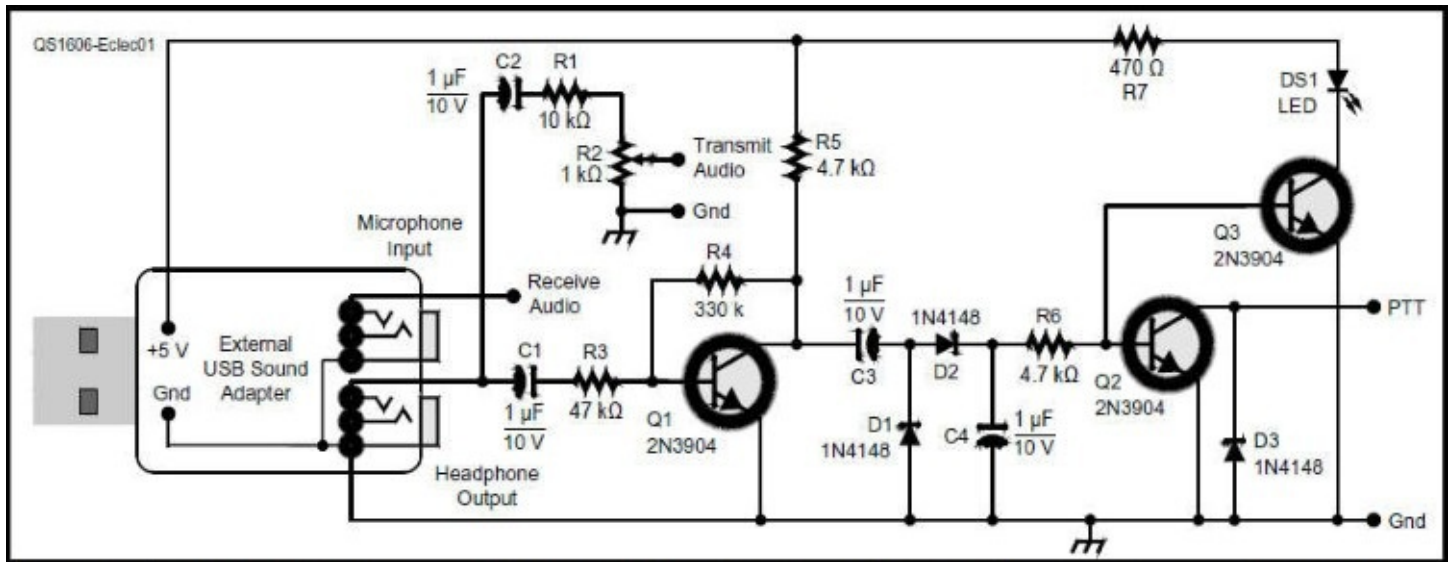

Figure A – The G4ILO digital communications interface. The heart of the interface is an inexpensive external sound adapter. The accompanying circuitry is used to channel the transmit and receive audio, and key the transceiver. Mouser Electronics part numbers shown ([www.mouser.com](http://www.mouser.com)).

C1, C2, C3, C4 – 1 µF ceramic disc capacitors (810-FK24X5R1C105K)

D1, D2, D3 – 1N4148 diodes (512-1N4148)

DS1 – Red LED (78-TLCS5100)

Q1, Q2, Q3 – 2N3904 transistors (610-2N3904)

R1 – 10 kΩ, ¼ W resistor (791-RC1/4-103JB)

R2 – 1 kΩ potentiometer (652-PDB181K415K102A2)

R3 – 47 kΩ, ¼ W resistor (791-RC1/4-473JB)

R4 – 330 kΩ, ¼ W resistor (791-RC1/4-344JB)

R5, R6 – 4.7 kΩ, ¼ W resistors (791-RC14-472JB)

R7 – 470 Ω, ¼ W resistor (603-CFR-25JR-52470R)

PSK31 transmits its binary code in an interesting way. Instead of keying the signal on and off, PSK31 uses Digital Signal Processing to create an audio signal that shifts its *phase angle* 180° in sync with the 31.25 bit-per-second data stream. A 0 bit in the data stream generates a phase shift, but a 1 does not. So, PSK31 software uses two phase angles (0° or “in phase” and 180° out of phase) to communicate 1s and 0s. Because two phase angles are used to accomplish this, it is usually referred to as *binary* phase-shift keying, or BPSK (most people use the term “PSK31” as a kind of catch-all label).

It’s terrific performance notwithstanding, PSK31 will not always provide 100% copy; it is as vulnerable to interference as any digital mode. And there are times, during a geomagnetic storm, for example, when ionospheric propagation will exhibit poor frequency stability. When you are trying to receive a narrow-bandwidth, phase-shifting signal, frequency stability is very important.

## ***The Panoramic Waterfall***

One of the early bugaboos of PSK31 had to do with tuning. Most PSK31 programs required you to tune your radio carefully, preferably in 1 Hz increments. Regardless of the software, PSK31 tuning required practice. You had to learn to recognize the sight and sound of your target signal. With the weak warbling of PSK31, that wasn’t always easy to do. And if your radio didn’t tune in 1 Hz increments, the receiving task became even more difficult.

Nick Fedoseev, UT2UZ and Skip Teller, KH6TY, designed a solution and called it *DigiPan*. The “pan” in *DigiPan* stands for “panoramic.” With *DigiPan*, the idea is to eliminate tedious

tuning by detecting and displaying not just one signal, but *entire groups of signals*.

If you are operating your transceiver in SSB without using narrow IF or audio-frequency filtering, the bandwidth of the receive audio that you're dumping to your sound device ranges from about 100 Hz to 3000 Hz. As you might imagine, with a bandwidth of only 31 Hz, many PSK31 signals can squeeze into that 2900 Hz chunk of spectrum. Panoramic software acts like an audio spectrum analyzer, continuously sweeping through the received audio spectrum and showing you the results in a large *waterfall display* that continuously scrolls from top to bottom. What you see on your monitor are vertical lines of various colors that indicate every signal that the software can detect. Bright lines represent strong signals while faint lines indicate weaker signals.

Other software writers jumped on the panoramic bandwagon, and soon, nearly every PSK31 program used waterfall displays of one type or another. The beauty of panoramic reception is that you do not have to tune your radio to monitor any of the signals you see in the waterfall. You simply switch your transceiver to the USB mode and tune to a popular PSK31 frequency. As the PSK31 signals “flow” down the waterfall, you move your mouse cursor to the signal of your choice and click. A cursor appears on the trace, and the software begins displaying text. You can hop from one signal to another in less than a second merely by clicking your mouse.

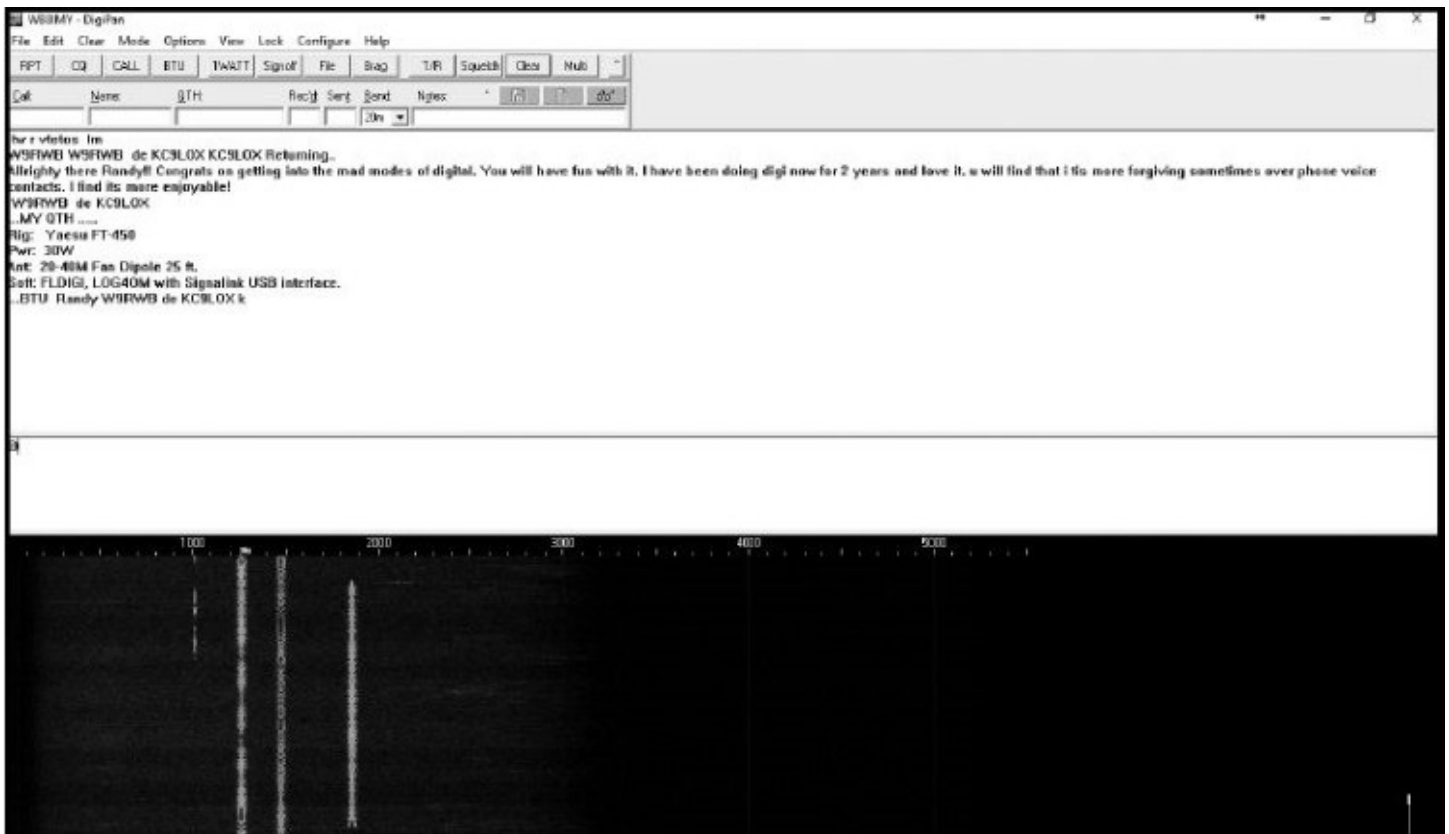

*DigiPan* is a simple *Windows* application for operating PSK31. You can download it free of charge at [www.digipan.net](http://www.digipan.net). You will also find it available at [www.arrl.org/hf-digital](http://www.arrl.org/hf-digital).

## Getting on the Air with PSK31

Let's take a step-by-step approach to setting up your indoor PSK31 station. Because I'll assume that you are new to HF digital, we'll use *DigiPan* software for *Windows* as our

example. *DigiPan* is free to download at [www.digipan.net](http://www.digipan.net) and it is easy to understand. *DigiPan* runs well on every version of *Windows*.

If you are a Mac owner, I'd recommend you start with W7AY's *Cocoamodem*, which is available free of charge at [www.w7ay.net/site/Applications/cocoaModem/](http://www.w7ay.net/site/Applications/cocoaModem/). *Linux* users may want to start with *Fldigi* at [www.w1hkj.com/download.html](http://www.w1hkj.com/download.html). Both are multimode programs that offer PSK31, but many of the same ideas you'll learn about *DigiPan* apply to multimode software as well, only the labels and menus may change.

We'll begin by assuming that you've installed *DigiPan* on your hard drive. When you run *DigiPan* for the first time, it will ask you to fill in your call sign, name and location (QTH). Go ahead and do so. You can leave the CW ID box unchecked.

## ***Setting Up DigiPan to “Talk” to Your Interface***

For this discussion, I'll assume that you are using an interface of some sort. *DigiPan* will work with any of the interfaces we've discussed, including those built into transceivers. However, you'll need to configure *DigiPan* to talk to the interface. You only need to do this once, but it is an important step.

Once you have *DigiPan* up and running, click **Configure** and then click **Sound card**. In the little window that appears, you want to make sure that the sound device **Type** is correct. This is typically listed as “Computer Sound Card.” In this same window, and even more importantly, make sure *DigiPan* is using the correct audio inputs and outputs. For example, if you are connecting the transceiver's receive audio to the **Line Input** of your computer sound card, make sure that the **Line Input** has been selected. If you are using an interface with a sound device built in, look for “USB Audio CODEC,” or something similar, in the drop-down list and select this for both the input and the output. Don't worry about the Sample rate window.

In the *DigiPan* **Configure** menu, click **Serial port**. Here is where you'll select the computer port you will use for Push-to-Talk (PTT) to key the transceiver. Highlight the COM port your interface is using. If you have an interface with a USB cable, or if you are using a USB-to-serial adapter, you need to select the “virtual COM port” number. To find this mysterious number, track down *Device Manager* (it is present in all modern versions of *Windows*). Open *Device Manager* and look for the *Ports* listing. “Expand” the list (click on the + sign) and you will find the virtual COM port for your interface or adapter cable. Make note of the COM number, and then go back to *DigiPan* and select that COM port number in the **Serial port** menu. If you use an audio-sensing interface, such as the G4ILO design described in this chapter, choose **NONE**.

### **“Sound Card is in Use or Does Not Exist”**

There is a potentially vexing oddity that can occur with some sound device *driver* applications. A driver is a small piece of software that is dedicated to a specific task, typically “talking” to various devices inside or outside the computer. A driver acts as the

liaison between the software and the device the software is attempting to use. For example, a printer driver is the liaison between a word processing program and the printer hardware.

In an effort to provide more user convenience, some sound device drivers attempt to detect when something (such as a microphone) has been plugged into the computer's audio port. In theory, the drivers should then automatically route the audio signals to the software accordingly. This is a fine concept, but it can cause headaches for HF digital software users, particularly those folks using older interfaces that do not include sound devices.

The pain occurs when you start your HF digital application (such as *DigiPan*) and instantly receive an error message telling you that the "Sound card is in use or does not exist." This happens because the driver isn't allowing your HF digital software to gain access to the audio data from the computer's sound card. Fortunately, the solution is simple: (1) Shut down the software, (2) plug in the audio cables from the interface, and (3) restart the software. Now the driver will be satisfied and will allow your HF digital software to access the sound card.

Also, check the boxes labeled **RTS as PTT** and **DTR as PTT**. By doing so, you're telling *DigiPan* to send keying pulses on both the Request to Send (RTS) and Data Terminal Ready (DTR) lines on the COM port. Your interface will be looking for the PTT keying signal from one of these lines; by checking both boxes, you'll cover all your bases, so to speak.

There are many other features you can configure in *DigiPan* to customize it to your liking, but these will be sufficient to get you started.

---

**Table 1.1**  
**Popular PSK31**  
**Frequencies**

3580 kHz  
7070 kHz  
10140 kHz  
14070 kHz  
21070 kHz  
28120 kHz

---

## ***Receiving PSK31***

Turn on your transceiver, select Upper Sideband (USB) and tune to one of the PSK31 frequencies shown in **Table 1.1**. During daylight hours, 14.070 MHz is a good choice. If propagation conditions are favorable, you should hear the warbling sounds of PSK31 signals. Leave your transceiver VFO alone from this point onward.

Look at the waterfall display (the bottom window) in *DigiPan*. If everything is working properly, you should see a screen similar to **Figure 1.3**. Each line represents a signal.

If your waterfall display is showing only faint blue lines or nothing at all, this means that not enough receive audio is getting to the sound device in your interface or computer. If the waterfall window is utterly black, the first things to check are your audio cables. Make sure

they are plugged into the correct ports.

If you are using an interface that has receive and transmit audio controls on the front panel, make sure the receive audio control is turned up. If your interface lacks audio controls, it is time to look at the sound controls in your computer.

You can access the sound input level controls in *DigiPan* by clicking on the **Configure** menu, followed by **Waterfall drive**. However, this function only works if your computer is running *Windows XP*. If you are using *Windows 7* or beyond, you'll need to jump through several hoops. From your *Windows* Start menu, open the **Control Panel** and double click on the **Sound** icon. In the window that opens next, click the **Recording** tab.

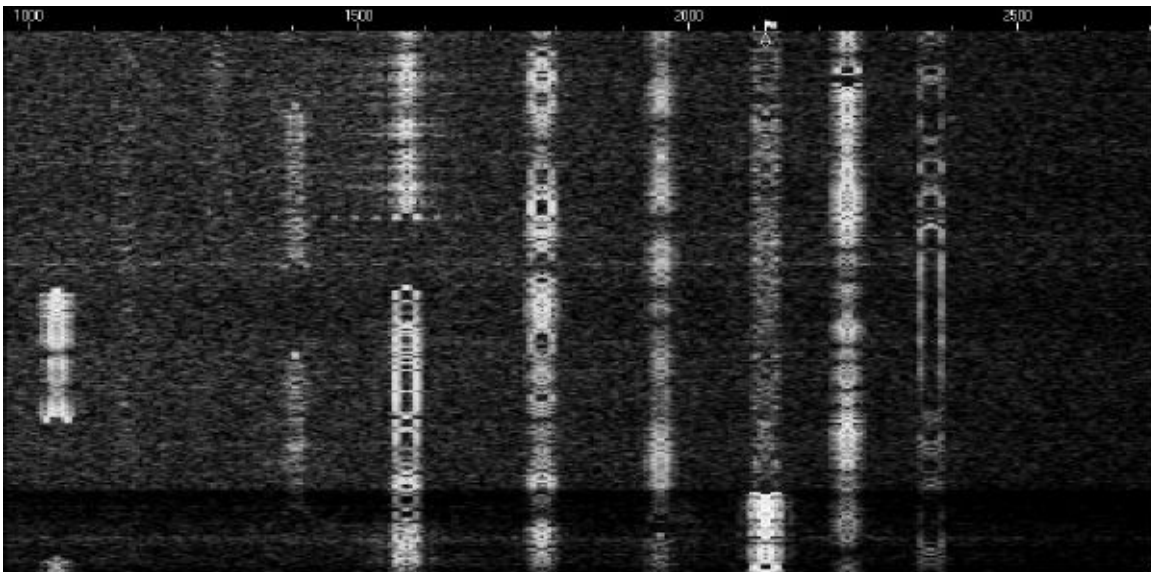

**Figure 1.3 – A PSK31 waterfall display. Each line represents a PSK31 signal.**

Now you'll be presented with a list of all the audio inputs and devices that *Windows* “knows about.” The audio input or external sound device should be highlighted. It may also include a checkmark. If the correct input or device is not highlighted, click on it now.

With the device highlighted, click on the **Properties** button, and you'll be presented with yet another window. Click the **Levels** tab, and you'll finally see the slider control that will allow you to increase the audio input level. If it is at minimum, turn it up (slide it up or to the right).

If all is well, you should now see blue or yellow lines moving from top to bottom in the waterfall window. If the waterfall window is filled with a yellow haze and the signal lines are mostly red, you have too much audio. Reduce the receive audio level until only the strongest signals appear as yellow lines.

Examine the waterfall window closely. Do you see the numbers 1000, 2000 and 3000 along the top of the window? These are audio frequencies in Hertz (Hz). You may also notice that the blue haze in the waterfall is somewhat brighter at the far left and that it fades to black at the far right, probably just beyond the 3000 Hz marker.

What you are seeing is the entire audio bandwidth of your radio's receiver, ranging from 100 to about 3000 Hz. The waterfall haze is brighter at the lower end because the audio response of your radio is stronger there. If you own a transceiver that allows you to adjust

receiver audio equalization, you can tweak it for a more uniform response from low to high frequencies, although this isn't really necessary for using *DigiPan*.

If you want to try something educational, switch in a narrow transceiver IF filter (such as a CW filter) while watching the waterfall display. You may be able to do this by simply switching your radio to the CW mode. You'll see the waterfall haze suddenly become much narrower according to the width of the filter. You'll also notice that all the other signals outside the filter bandwidth have vanished. This is a powerful illustration of how beneficial a narrow IF filter can be.

Switch back to USB and click your mouse cursor on one of the signal lines. You should be rewarded with text flowing across the top window. To tune to a different signal, all you have to do is click your mouse cursor on another line.

It is important to emphasize here that you are *not* tuning your radio as you hop from one signal to the next. Your radio's VFO display remains fixed at 14.070 MHz. That's the magic of panoramic reception within an audio bandwidth. Because a panoramic display frees you from the need to tune your radio, it is probably a good idea to lock your VFO if your radio provides that option. This will prevent you from accidentally bumping the knob and sifting frequency.

If you have several visible signals in the waterfall window, here is something fun to try. *DigiPan* offers a unique *multichannel* view that you can activate in the **View** menu. When this feature is active, *DigiPan* will attempt to simultaneously decode every signal in the waterfall! This makes for a fascinating, if somewhat chaotic, display.

Using the waterfall display, you may often see (and copy) PSK31 signals that you cannot otherwise hear. It is not at all uncommon to see several strong signals (the audible ones) interspersed with wispy blue ghosts of very weak, "silent" signals. Click on a few of these ghosts and you may be rewarded with text (not error-free, but good enough to understand what is being discussed).

In the lower right corner of the waterfall window, you'll notice green or multicolored lines that seem to move rapidly. This is the phase display. When you click on a strong BPSK signal, you'll see the lines turning green and aligning vertically (more or less). This is an indicator of how well *DigiPan* is decoding the binary phase shifts, so you can consider the display as an indicator of signal quality. With a perfect BPSK signal, the green lines will be perfectly vertical. Of course, perfect conditions are uncommon, so you'll usually see the green lines flickering all over the place. If the signal is terrible or very weak, the lines will be anything but vertical!

You don't need to pay attention to the phase display during normal operation, but it can occasionally tell you some interesting things. As an example, let's say that you've clicked your mouse cursor on what seems to be a strong signal, but the resulting print is garbled at best. Glance at the phase display. If the lines are flickering chaotically around the circle, this means that while the signal may be strong, the phase relationships are badly disrupted. This can occur when receiving signals that have come to you from over the Earth's poles and are suffering from "polar flutter." You'll see the same thing when receiving PSK31 from nearby stations whose signals are arriving at your antenna along several different pathways and partially canceling each other out ("multipath distortion").

## *Time to Tune*

Now that you've spent some time decoding PSK31 conversations, no doubt you'll be eager to transmit. Look at the waterfall display and try to find an open spot between the signal lines. Click your mouse cursor on one of those empty spaces. You've just chosen your transmit frequency.

When you transmit, the PSK31 software generates a tone that corresponds to the frequency "position" in the waterfall where you clicked your mouse cursor. (Again, see the audio frequency scale along the top of the *DigiPan* waterfall display.) When that tone is applied to your radio, it creates an RF signal on the correct frequency – a certain number of Hertz above or below the suppressed carrier frequency. In the **Configuration** window you can set up *DigiPan* to display either the tone frequencies or the corresponding RF frequencies in the waterfall.

It is worthwhile to note that the frequency your transceiver displays in the SSB mode is the *suppressed carrier frequency*. If you've selected upper sideband on your radio (USB), your receive audio range is everything from the suppressed carrier frequency to about 2 or 3 kHz above it. That's what you are seeing in the waterfall display. *DigiPan* is continuously sweeping through this range and displaying the results. If you select lower sideband (LSB), your receiver range extends 2 or 3 kHz *below* the suppressed carrier frequency.

Let's check your audio and RF output levels before we do anything else. Switch your transceiver's meter to ALC. Now click the **Mode** button along the top of the *DigiPan* window and select **Tune**.

Your transceiver should jump to the transmit mode and stay there. Using your interface controls or your audio output control in *Windows* (this may appear as a tiny speaker icon in the lower right corner of the *Windows* desktop), increase the audio level until you *just* see ALC activity, then reduce the level until ALC activity ceases. If your transceiver meter uses an ALC "zone" instead, increase the audio level until the needle moves to the higher end of the zone.

Now, quickly switch the meter to display RF output power. You should see a substantial percentage of the full RF output according to the power level you've set on transceiver: 10 W, 5 W or whatever. Click **OK** in the **Tune** window to unkey your transceiver.

It is possible that you may see less RF output than you anticipated. This can be caused by the way the ALC function works in your particular radio; even minimal ALC activity may result in reduced output. Another possibility involves the *transmit audio response* of your radio. A brief explanation is in order.

## *Transmit Audio Response*

Let's say you've chosen a transmit "location" in the *DigiPan* waterfall display that corresponds to an audio tone of 1000 Hz. When you transmit, your sound device will send a 1000 Hz tone to your radio. Since you are operating in Upper Sideband (USB), your radio will generate an RF signal 1000 Hz above the suppressed carrier frequency shown on the transceiver's display. If the display reads 14.070 MHz, you will be transmitting at 14.071 MHz (14.070 + 1000 = 14.071 MHz).

If you select a point in the waterfall that corresponds to 300 Hz, your radio will transmit at 14.0703 MHz ( $14.070 + 300 = 14.0703$  MHz). So far so good.

You'd think that your RF output level would be the same regardless of whether you sent a 1000 Hz or 300 Hz tone to the radio, but you'd be wrong. The transceiver has a *response curve* that limits the degree to which the various audio frequencies are amplified before they are converted to RF. It applies to audio coming in at the accessory port or microphone jack. This response curve can differ from one brand of radio to another. In some radios, it can be changed through a feature often referred to as "transmit audio equalization."

Generally speaking, the response tends to roll off at the high and low ends of the audio range. See **Figure 1.4**. What this means to you is that the strength of an audio tone at the low or high ends of the curve will be reduced within the transceiver before it becomes RF. The result will be reduced RF output, even though the audio level from your sound device hasn't changed.

What can you do? There are a couple of options ...

- Adjust your sound device output level to compensate.
- Find an open transmit frequency that is closer to the middle portion of the waterfall (around 1000 Hz).

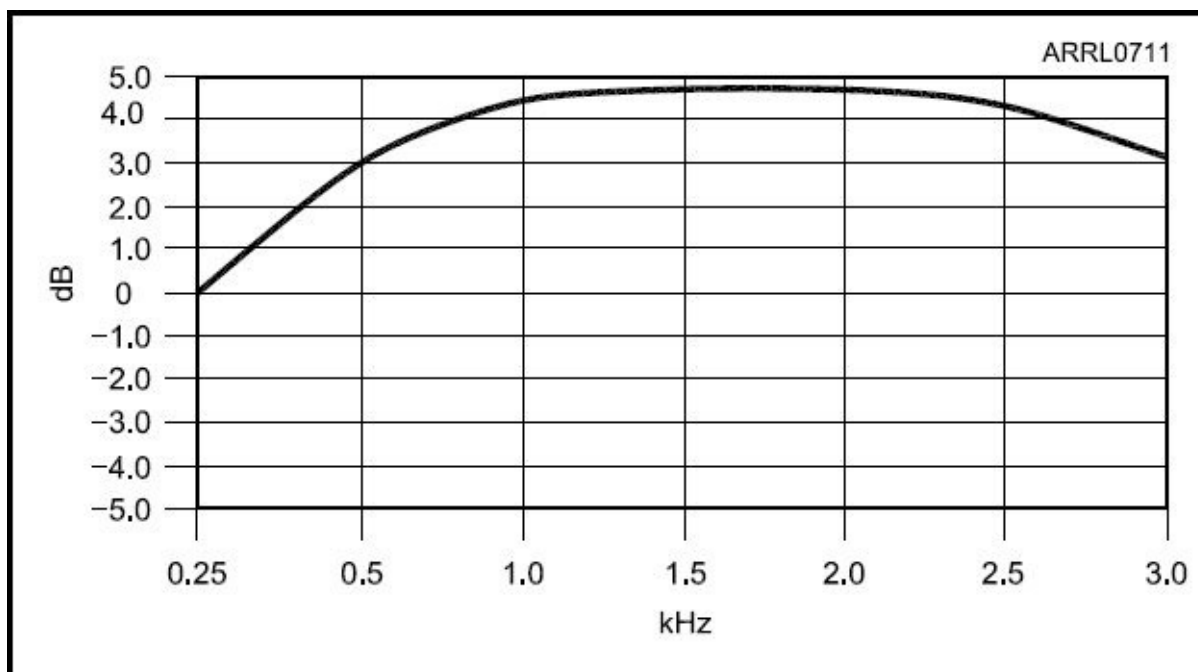

**Figure 1.4 – The transmit audio frequency response of a typical transceiver. Notice how the curve drops at the high and low ends. If you applied a 300 Hz tone to the radio, for example, the resulting RF output will be lower than if you applied a 1000 Hz tone. This is the reason why you'll see your output changing, depending on where you choose to set your transmit frequency in the waterfall.**

If you encounter this behavior when you find an interesting station whose signal is at the extreme edge of the waterfall (high or low), another approach is to gently adjust your transceiver VFO, while watching the waterfall, and then "move" the signal closer to the middle of the display.

Of course, the final option is to simply ignore the issue. PSK31 doesn't require much RF to



work successfully, so reduced output probably won't make that much difference.

## *Calling CQ*

There are two ways to call CQ in *DigiPan*. One method, the one we'll discuss here, is best described as the "manual method." There is a more automated approach that we will address later.

For now, click your mouse cursor in the middle window of *DigiPan*. This is your *transmit buffer*. Everything you type in this window will be sent when it is time to transmit. Type the following, substituting your call sign for mine, of course ...

**CQ CQ CQ CQ WB8IMY WB8IMY WB8IMY CQ CQ CQ CQ WB8IMY WB8IMY WB8IMY CQ K**

Now, click the **T/R** button in the *DigiPan* tool bar. Your radio should pop into the transmit mode and begin sending your CQ message. You'll see your wavering RF output, and you will also see the transmitted text in the upper receive window. Watch this text closely. When you see the "**K**" appear ("over" in Morse code), quickly click the **T/R** button again to place your radio back in the receive mode.

Now we wait! With luck someone will respond ...

**WB8IMY WB8IMY DE W1BXY W1BXY W1BXY K**

From this point, the conversation proceeds in turns. You type your reply in the transmit buffer and click **T/R** to send the text, and then wait for his response.

**W1BXY DE WB8IMY . . . Thank you for the reply. Name is Steve and I am in Wallingford, CT. Your RST is 589. How copy? W1BXY DE WB8IMY K**

*DigiPan*, like most HF digital programs, allows you to type in the transmit buffer while you are receiving. This is a *very* handy function – especially if you are a slow typist. As the other station transmits, you can read his text and type comments in your transmit buffer as you go. When it is your turn, just click on the **T/R** button, and everything you've typed will be transmitted. At his end, you'll look like the world's fastest, smoothest typist!

## *Macros*

So far, we've discussed the manual method of sending PSK31 text with *DigiPan*. Now, it is time to introduce a bit of automation with *macros*.

The word "macro" is from the Greek *μακρό* for "big" or "far." In the digital world, a macro is a single instruction that causes an entire set of actions (or instructions) to take place. For HF digital software, a macro is used to send preformatted "canned" text.

Macros are commonly used during contests when you are tasked with sending the same text repeatedly. DX stations also use macros to send exchanges automatically when they need to work as many stations as possible, as quickly as possible. Hams in other countries will often rely on macros when they are not fluent in English. They prepare several text messages as macros so that they can send understandable English quickly and accurately.

A macro can be as simple or complex as you desire. *DigiPan* comes with several macros preformatted. These appear as buttons near the top of the window.

With your mouse, *right click* on the **CQ** button. A window will open to show you the preformatted macro (see **Figure 1.5**). The text that appears inside the “less than” and “greater than” symbols (< and >) is interpreted by *DigiPan* as a command, not as text to be sent.

**<TX> CQ CQ CQ DE <MYCALL> <MYCALL> <MYCALL> pse K <RXANDCLEAR>**

Strange as it may look, this is a straightforward macro. Let’s break it down ...

**<TX>** This is a command to place the radio in the transmit mode.

**CQ CQ CQ DE** This is plain text to be sent.

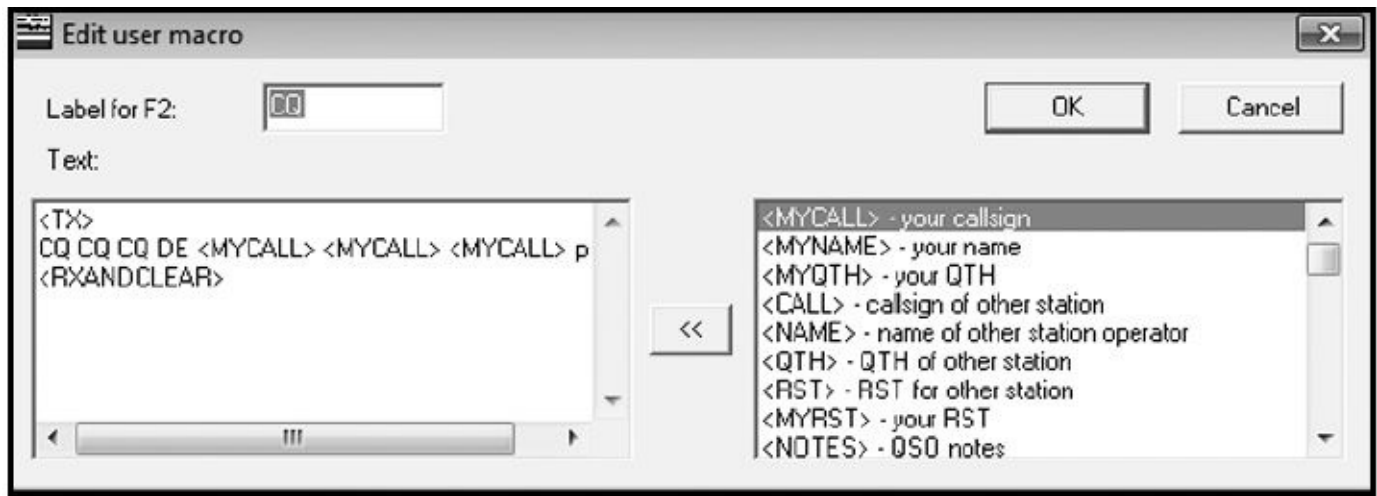

**Figure 1.5 – In *DigiPan* (and most other digital applications), there are macros that you can use to send strings of text, such as a CQ call. Rather than typing out the entire CQ over and over, you only need to set it up once as a macro, and then send it with the single click of a button.**

**<MYCALL>** This is a command to insert your call sign. It repeats three times.

**Pse K** More plain text

**<RXANDCLEAR>** This is a command to return the radio to the receive mode and clear (erase) the transmitted text from the transmit buffer so that it won’t accidentally be sent again.

As you can probably see, the **T/R** button is also a macro. When you click on it, the **TXTOGGLE** command executes. This places the radio into transmit mode and then waits for you to click the button again to return to the receive mode.

If you right click on one of the macro buttons again and browse the scrolling list of commands along the right-hand side of the window, you’ll quickly realize that you can create some incredibly elaborate macros. Contest macros, for example, can automatically send the other station’s call sign, a signal report and a serial number that increments by one with every contact – all with a single click of your mouse.

Be careful about relying too much on macros. They are convenient – especially the CQ macro — but they can also cause confusion if used improperly. In addition, some hams create macros that contain lengthy descriptions of their station equipment, families, etc. It’s tempting to tap that macro key and sit back while your computer sends more information than the other person really wants to know!

Finally, many amateurs complain – and with some justification – that overreliance on

macros takes the pleasure out of making contacts. A contact based on macros is little more than a brief exchange of canned text. A ham who is expecting a leisurely chat will be gravely disappointed if all you do is send a few macros instead.

# Indoor Antenna Designs

Let's start with wire. The nice thing about wire is that you can bend and shape it to fit your requirements. Even the smallest indoor rooms can accommodate an HF wire antenna if you are willing to be creative.

The easiest indoor wire antenna is the dipole – a center insulator (where the feed line attaches) and two wires of equal length. If you only care about operating on one band, you can try a single-band half-wavelength design. The classic formula to determine its length is:

**468 / Frequency (MHz)**

However, this formula was created with outdoor antennas in mind. It doesn't take nearby wood, drywall, electrical wiring or heating ducts into account. You can use the formula to get into the ballpark, but count on having to lengthen or shorten the wires considerably as you tweak the antenna for the lowest SWR.

Unless you live in a mansion with enormous rooms, some folding of the dipole will be necessary. The final shape of the antenna will depend on the dimensions and configuration of the room. Remember that the center of the dipole carries the most current and therefore does most of the radiating. This part should be as high and unfolded as possible. Because the ends of the dipole radiate less energy than the center, their orientation is not as important. They do carry the maximum voltage, however, so care should be taken to position the ends far enough from other conductors to avoid arcing, or contact with people or animals.

The dipole may end up being L-shaped, Z-shaped, U-shaped or some indescribable corkscrew shape, depending on what space is available. As an example, consider the 20-meter dipole shown in **Figure 2.1**. Using the formula, we find that each leg is about 16 feet in length, yet it can squeeze into a small 10 × 10-foot bedroom with some creative folding.

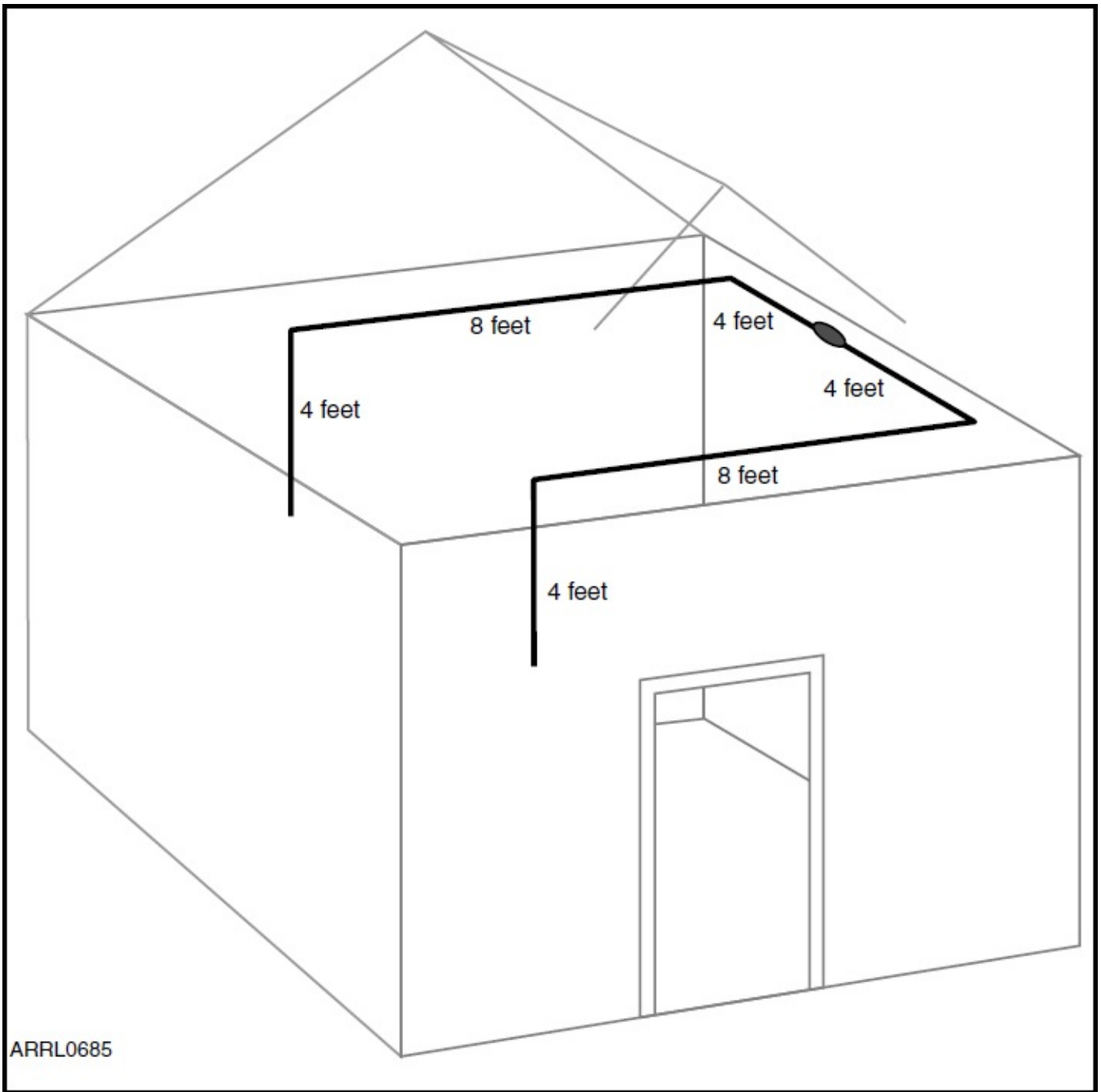
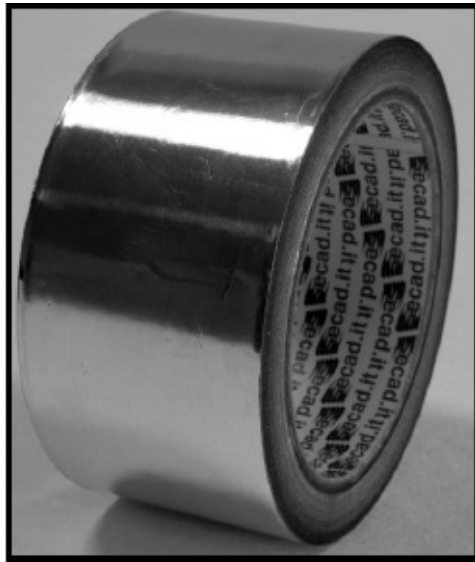

Figure 2.1 – Even a dipole antenna for the 20-meter band can fit into a small room with a bit of folding.



**Metallic adhesive tape can be an alternative to using wire for indoor antenna elements**

I used an antenna like this to work many stations from a two-story apartment while running about 20 W output (mostly CW at the time). To keep my wife happy, I made the dipole out of ordinary two-conductor speaker wire that I painted white to match the walls and ceiling. White thumbtacks held the wires along the corners where the walls met the ceiling. I even painted the coaxial feed line white to help camouflage it against the drywall. An alternative to consider, if you are running low power, is flat metallic adhesive tape. It comes in large rolls and is easy to stick to a wall.

The most difficult aspect of setting up a single-band resonant dipole is trimming it for lowest SWR. You have to add or subtract wire in equal lengths from each leg of the antenna while taking SWR measurements to observe the results. On the other hand, one of the great things about indoor wire antennas is that they are easy to adjust – no need to climb ladders or brave inclement weather.

So what if you want to operate on more than one band with your wire antenna? One approach is a variation on the venerable fan dipole that essentially amounts to two or more dipoles attached to the same feed point (see **Figure 2.2**). When used outdoors, a fan dipole can present a challenge because the individual wire dipoles tend to interact, making adjustment an exercise in frustration. One way to reduce interaction is to have the dipoles arranged at right angles to each other.

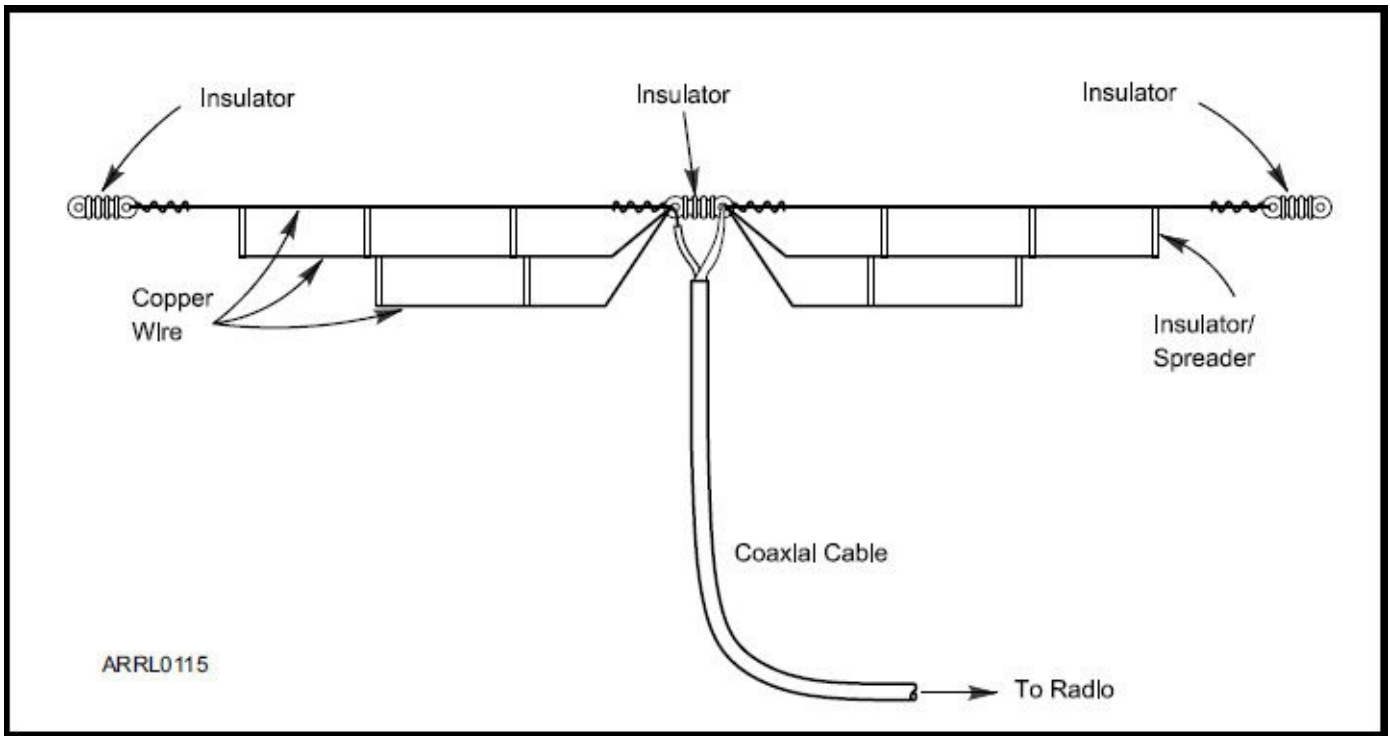

**Figure 2.2** – The classic fan dipole brings several dipoles together at a single feed point. You could use this same approach to installing several resonant antennas within a living area or attic. There are two downsides, however: (1) Having this type of multi-element antenna in a living space would impose on the overall décor of the room, to say the least, and (2) fan dipole designs are notoriously difficult to trim for the best SWR on every band due to interaction between the wires.

Indoors, separating the dipoles can be a difficult proposition, but not impossible. **Figure 2.3** illustrates a design that makes the best use of two rooms. In this example, the 20-meter dipole is installed and folded into one room. The 15-meter dipole attaches to the same feed point, but extends into the adjacent living room (more small wires and white paint).

Figure 2.3 – In this example of a multiband antenna, we have a 20-meter dipole in one room and a 15-meter dipole in an adjoining room – both connected at the same feed point. There may be some interaction between the parallel wires, so trimming for lowest SWR may be a challenge.

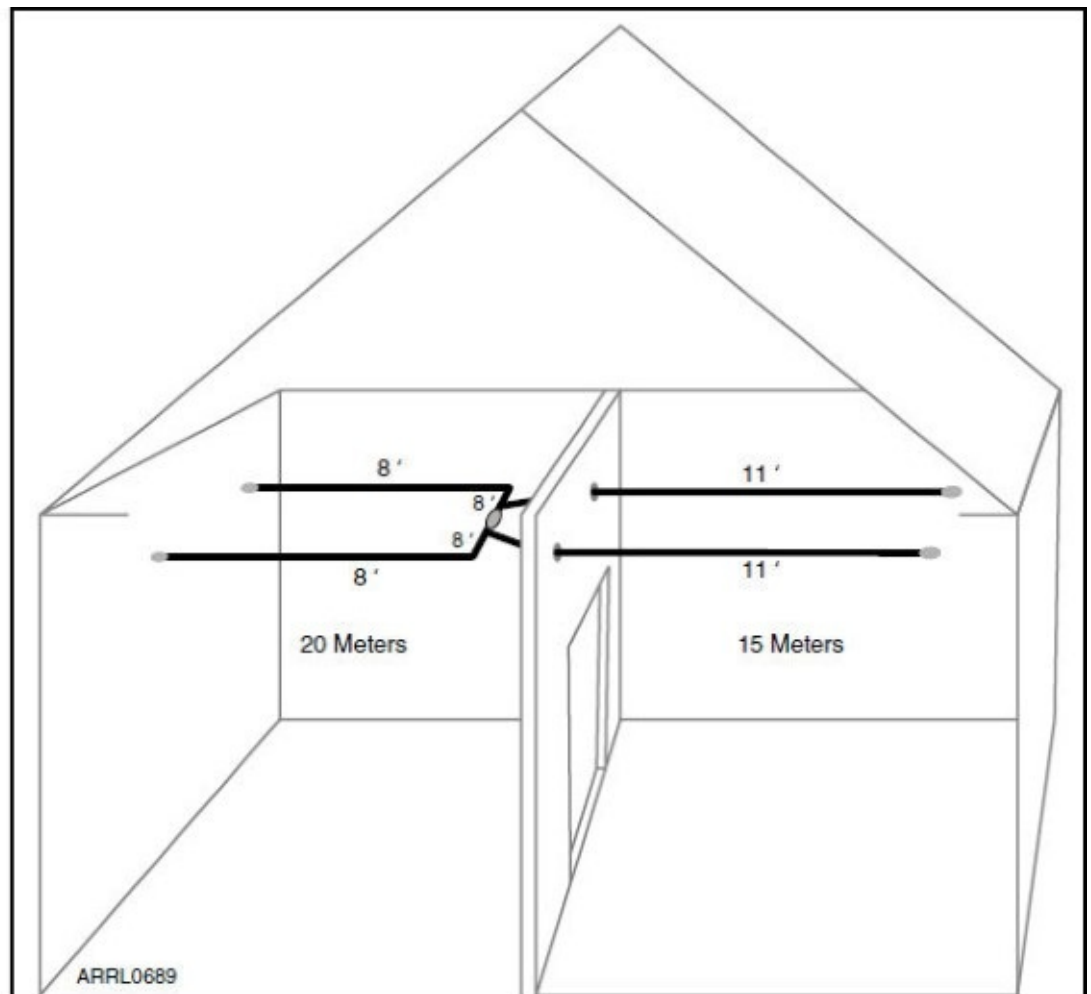

The easiest way to get multiband performance from a wire dipole antenna is to use an antenna tuner. See **Figure 2.4**. Here we have a 20-meter dipole along the ceiling, but notice that it is being fed with 450  $\Omega$  windowed ladder line rather than coaxial cable. Instead of the feed line snaking all the way back to the transceiver, it connects to the antenna tuner (a tuner with a balanced output port). The tuner, in turn, connects to the transceiver. You can use a setup like this to operate on any frequency at which the antenna tuner can provide a sufficiently low SWR for your radio. Because you are using a short length of ladder line, the losses between the tuner and the antenna caused by high SWR are almost irrelevant. In fact, as long as the distance between the feed point of the antenna and the antenna tuner is 10 feet or less, you can just as easily use coaxial cable rather than windowed ladder line. Yes, the loss due to SWR will be higher with coaxial cable, but the difference won't be horrendous.



**Figure 2.4 – A multiband ceiling dipole fed with 450  $\Omega$  ladder line. Unlike a tuned dipole, the length isn't critical. As a rule of thumb, make each leg of the dipole as long as the space allows and make sure both legs are of equal lengths. Frankly, this is perhaps the easiest approach to multiband operation. With the antenna tuner handling the impedance mismatches, you don't have to be concerned about trimming the antenna for resonance.**

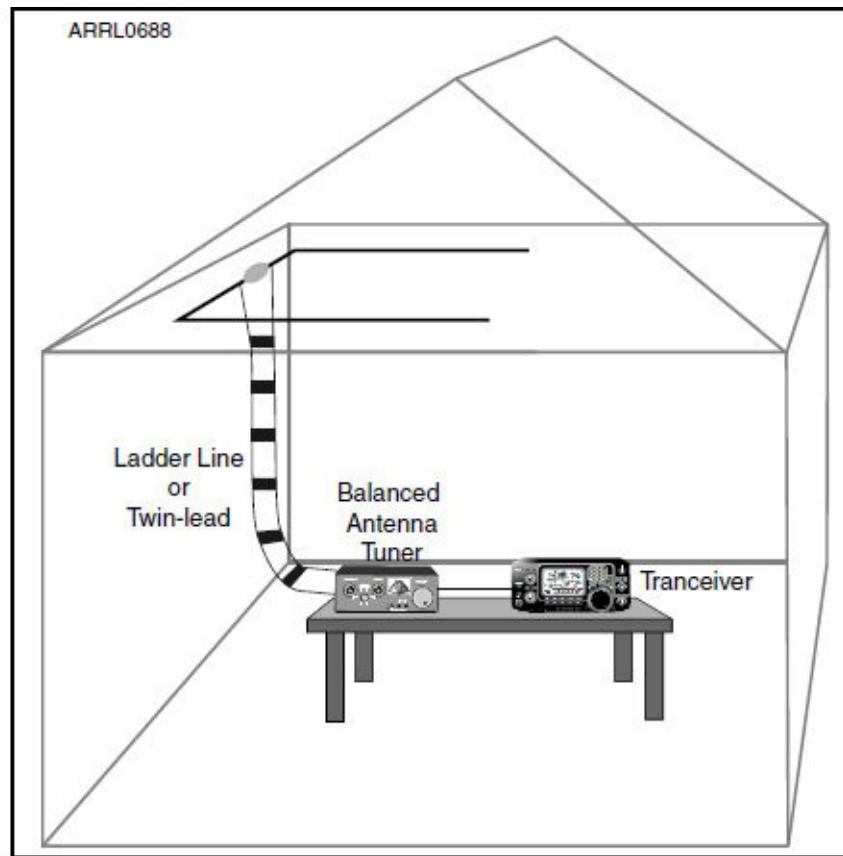

## **An Antenna Analyzer: One of your Best Investments**

If you like to play with different antenna designs, I'd strongly recommend investing in an antenna analyzer. These are wonderful devices for antenna experimenters. An antenna analyzer is essentially a low-power transmitter coupled to a circuit that analyzes the reflected power (among other things) and displays the SWR. With a twist of a knob or the push of a button, you can sweep through a wide frequency range and determine the point where the SWR is lowest.

Let's use a folded 20-meter wire dipole as an example. You've connected your trusty antenna analyzer and set it for 14.050 MHz – the frequency you want as the “center frequency” of your antenna. You press the button to measure the SWR and...*uh-oh!*...your analyzer is displaying a 12:1 SWR. It is time to conduct a sweep and determine what is really going on.

Some analyzers sweep through a range of frequencies automatically and display a handy SWR plot on an LCD screen; others require you to sweep manually. Let's say you try a manual sweep, slowly adjusting the frequency upward. Pretty soon you are beyond 16 MHz and the SWR just keeps climbing. This is a clear indicator that you need to reverse direction. As you sweep back down to 14.050 MHz and continue lower, you suddenly notice that the SWR is starting to fall. Keep going. Pretty soon the SWR is dropping below 3:1 and finally seems to bottom out at 1.5:1 at 13 MHz.

The analyzer is showing you that your dipole is actually resonant at 13 MHz, not 14.050 MHz. Because lower frequencies translate to longer antenna elements, your dipole is

obviously too long. Trim a few inches from each of the ends and sweep again. Soon you will see the low SWR point “moving” upward. Keep sweeping and trimming until you finally see a 1.5:1 SWR reasonably close to 14.050 MHz.

A good antenna analyzer will cost you around \$200 or more, but if you think you’ll be doing interesting things with antennas now and in the future, an antenna analyzer is well worth the investment. What you’ll spend for the instrument, you’ll save in time and frustration.



A Comet CAA-500 Mark II antenna analyzer.

If you want to have your radio in a separate room, but don’t want to run bulky, highly visible ladder line through your home, look at the alternative in **Figure 2.5**. The antenna tuner can reside in a discrete location near the antenna, but thin coax such as RG-58 can make the rest of the journey back to the transceiver.

The configuration in Figure 2.5 is not ideal. Every time you change frequency at the transceiver, you’ll probably have to go into the other room and adjust the antenna tuner. You can mark the positions of the tuner knobs to make this somewhat easier, but it is still an annoyance. The solution is to use a remote automatic antenna tuner (see **Figure 2.6**).

Depending on the type of automatic tuner you purchase, all you have to do is send a switching command from your radio or simply begin transmitting. The tuner will automatically seek the best SWR, and you won't have to move a muscle. Remote automatic tuners are also excellent devices for attic antennas, as you'll see later. Like the antenna analyzers, automatic tuners are not cheap. They typically cost \$200 to \$400. Even so, the sheer convenience is well worth the price.

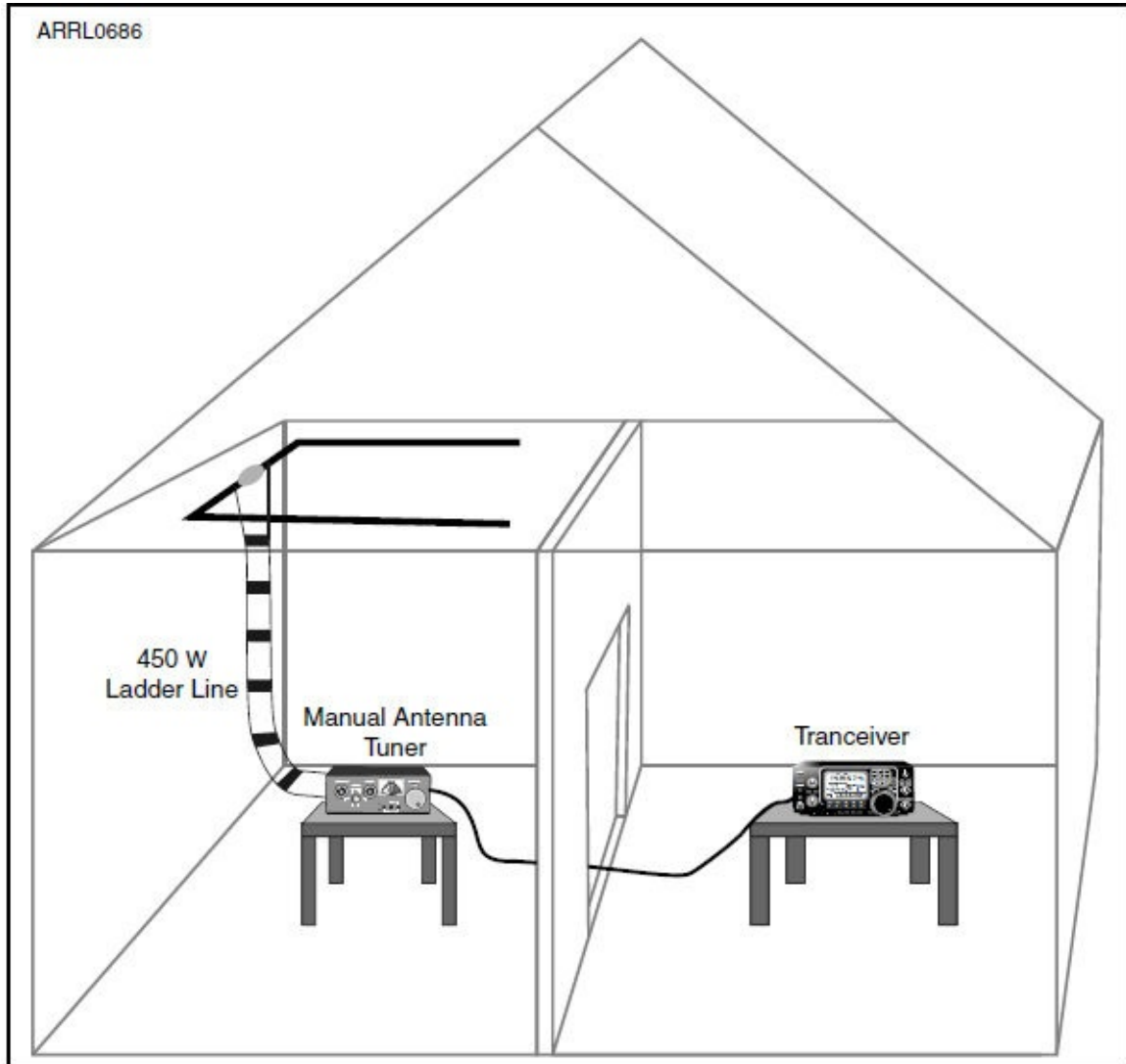

**Figure 2.5 – If your station and your multiband antenna are in separate rooms, consider placing the manual antenna tuner close to the antenna, feeding the antenna with 450  $\Omega$  ladder line and then using thin RG-58 coaxial cable between the tuner and the radio.**



**Figure 2.6 – An automatic antenna tuner will seek the best match automatically whenever you transmit. This type of tuner is extremely convenient when your antenna is located in a separate area, such as an attic. This particular model is the MFJ-927.**

So far, we've been talking about dipoles, but that isn't the only option for wire antennas inside your home. Another option to consider is the loop antenna.

A loop antenna is exactly as it appears to be. It is a loop of wire connected to the feed line, which must seem pretty strange at first glance. Looking at a loop antenna, it appears to be a dead short, electrically speaking. But on the contrary, when RF is applied to a loop of wire, it sees that wire not as a dead short, but as a load with a specific impedance. When you consider an ordinary room, you can see that there are many opportunities for loop antennas. Take a look at **Figure 2.7** for just one example. In this example, the loop wire travels along the edge of the entire ceiling, connecting to a short length of 450  $\Omega$  windowed line that attaches to an antenna tuner. This is the same type of balanced antenna tuner we discussed before. Despite the relatively small diameter of this loop, an antenna tuner with a wide tuning range should be able to find a match on several different bands. This same loop antenna could just as easily be installed vertically on the wall; it all depends on the layout of your house or apartment. As with all antennas, higher is always better. If you live in a structure with aluminum siding, attaching the loop antenna to the ceiling rather than the wall is the best choice.

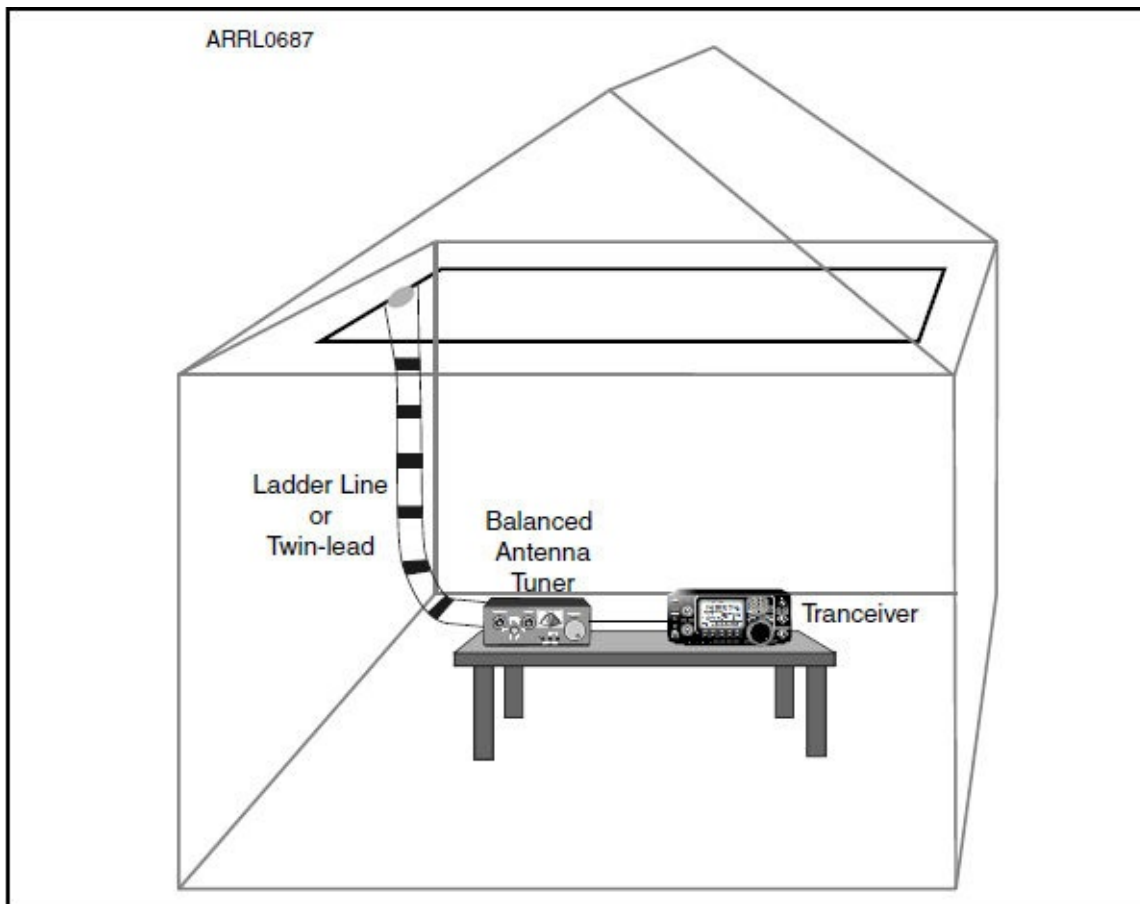
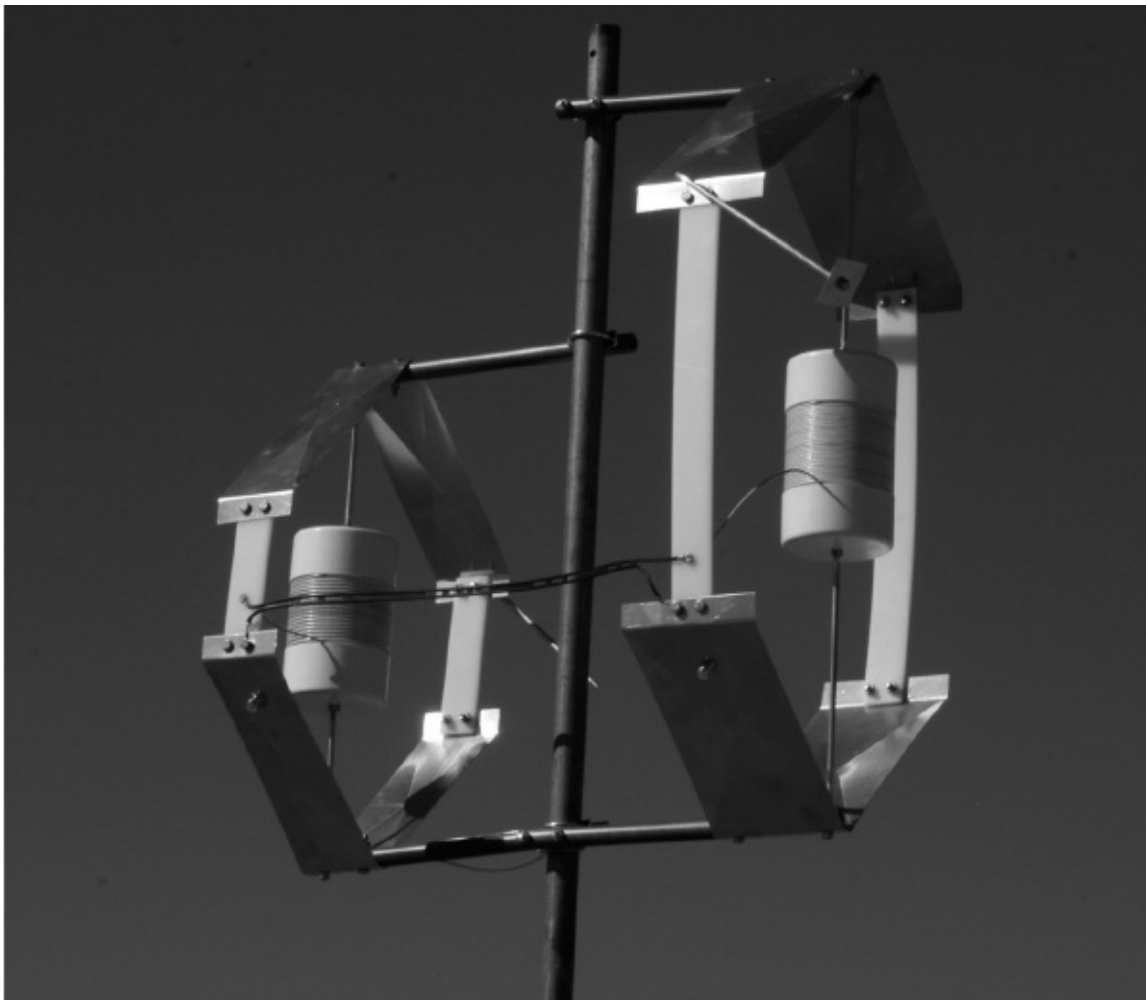

**Figure 2.7 – A loop antenna is a continuous circle of wire that attaches at either side of an insulator at the feed point. In this example, we have a loop installed within a room, typically on the ceiling. The loop should be as large as the room can accommodate. In this example, we’re feeding the loop with 450  $\Omega$  ladder line and an antenna tuner for multiband operation.**

## Commercial Antennas Indoors

Our discussion has centered on antennas that you have to build yourself, but you can just as easily use commercial antennas indoors as well. In fact, as long as the antenna is small enough to fit inside the room of your choice, any antenna can be used.

One idea to consider is a mobile antenna. Even though these antennas are designed for use on cars, they can function just as well without being attached to a vehicle. The difference is that instead of a car body acting as a ground plane, you must use radial wires or perhaps a single wire known as a counterpoise attached to the ground point of the antenna. Some mobile antenna manufacturers have anticipated that their products would be used this way, and they’ve provided supports such as tripods to make this possible. Depending on the mobile antenna design, you may need to adjust a tap or coil whenever you wish to change bands. However, other mobile antennas use motorized mechanical adjustments that can even be performed remotely using a small control box that you would keep by your radio.



Two Bilal Isotron antennas in a dual-band configuration. See [www.isotronantennas.com](http://www.isotronantennas.com).

It is interesting to note that you can also take two single-band mobile antennas and use them together as a dipole antenna. Manufacturers such as MFJ sell special mounting brackets that allow you to connect two mobile antennas together in this fashion. The mobile antennas screw into the bracket, and then you simply attach a coaxial feed line. As handy as this arrangement might be, two mobile antennas back to back can still make for a rather long dipole antenna. For example, two Hamstick-style mobile antennas together for the 20-meter band are approximately 14 feet in length. In addition, these antennas tend to be inefficient, lossy radiators. The 2:1 SWR bandwidth is on the order of about 150 kHz at best. Even so, they offer an alternative approach for indoor operating, especially if you have sizable attic space available.

There are other small antenna designs that do not require radials or any other type of ground system. One well known example is the Bilal Isotron antenna. The Isotron has been around for many years. Without oversimplifying, the Isotron is an extremely compact design comprised of a loading coil and metal plates (depending on the model). The Isotron can be placed on a short mast and set up just about anywhere in a room. Depending on how much power you're running, it is best to keep the Isotron well away from nearby objects and people.

Yet another antenna to consider for use indoors is a so-called magnetic loop. The antenna itself is not magnetic, except at very short distances. When used as a receiving antenna, however, it's said that the antenna primarily responds to the magnetic component of the

received signal. Magnetic loop antennas have been around for decades and are popular mainly because they are highly portable. During WWII and even throughout the Vietnam War era, the military used magnetic loop antennas for this very reason.

Compared to a dipole antenna, a magnetic loop antenna is not a very efficient radiator, but it can be effective when tuned properly. Perhaps the most popular commercially available loop is the MFJ-1788 Super Hi-Q loop. This magnetic loop is only about 4 feet in diameter, yet it can operate on every band from 30 through 10 meters. The antenna has a built-in tuning mechanism consisting of a large variable capacitor attached to an electric motor. By operating the motor by remote control, you can adjust the antenna for the lowest SWR. Like the Isotron, the MFJ loop does not require a ground system or radial wires. It does pose the same voltage and RF exposure concerns as an Isotron design.

Speaking of tuning, it is important to note that small antennas tend to have very narrow 2:1 SWR bandwidths. Magnetic loop antennas in particular can have extremely narrow bandwidths on the order of just a few kHz. You may find that you must frequently re-tune whenever you change frequency.



The MFJ-1786 is a small loop antenna with a remotely tuned capacitor to resonate it on 30 through 10 meters.

The type of indoor antenna you choose, of course, depends on your circumstances and the

size of your wallet. Wire antennas are obviously the least expensive, but for easy multiband operation, you may have to also invest in an antenna tuner. Yes, some transceivers have built-in tuners, but most of these do not have the impedance range necessary for the task.

And wire antennas don't lend themselves to being easily put up or taken down at a moment's notice. When you install a wire antenna in a room, you do it with the expectation that it is going to be there for a long time, hence the need to camouflage it — unless you have a very understanding spouse. Smaller freestanding antennas such as mobile antennas, the Bilal Isotron or the MFJ loop are much easier to set up or put away as required, but they may be more expensive than a simple do-it-yourself antenna.

## **Into the Attic**

If you're fortunate enough to live in a house, apartment or condo-minium that has an attic space, you may find that you have an excellent location for an antenna farm right over your head!

Attics in modern homes tend to be rather small. Count yourself lucky if you have an attic that will allow you to stand upright; most modern attics offer, at most, 4 or 5 feet of headroom between the attic floor and the peak of the roof. Attics in newer homes also tend to be unfinished. This means that instead of a floor you will find only lumber joists packed with insulation.

The truly lucky hams are the ones who live in older homes with large finished attics. Some of these old attics are rooms unto themselves with high ceilings, finished floors and plenty of horizontal space. Hams with attics like these have room not only for wire antennas, but even for small directional arrays.





An unfinished attic is a good hiding place for an indoor antenna. Take care to step only on the wood joists. The insulation is resting atop the sheetrock of the ceiling. As sturdy as it may be, sheetrock will *not* support the weight of an adult!

If you live in an apartment or condominium and you're on the top floor, it's time to do some detective work. Access to the attic is typically provided by a small door, a hatchway really, that you'll find tucked away in closet or utility room. In many instances, however, these attics are shared, which means that you don't have the attic all to yourself. Approach this type of attic with special care. If you're considering the idea of stringing a wire antenna along the length of the attic, keep in mind that you'll be walking right over your neighbor's rooms as you are putting it up. They aren't likely to appreciate this, and there is always the danger that your foot may slip off a joist, smash through the drywall and appear in their home as an uninvited guest. It is one thing to slip and punch a hole through your own ceiling; some handiwork with a drywall patch will set it right. Your neighbor won't be nearly as understanding!



Brad Bylund, WA6MM, installed an Alpha Delta DX-EE multiband antenna in his 40-foot-long attic. He feeds it with LMR-240 coaxial cable and finds that it works well on 10, 12, 15, 17, and 20 meters. He also added 14 clamp-on ferrites to the coax near the feed point to reduce any potential common mode currents on the feed line.

## **Attic Antenna Advice from ACØC**

Jeff Blaine, ACØC, once installed one of the most elaborate HF attic antenna installations known. With it, he worked a ton of DX and was a competitive presence in a number of contests – all with a ham station that was utterly invisible to his neighbors.

My #1 advice to guys working on attic antennas is to view the project as an iterative experiment. You won't know exactly what will work best until you try to build the first antenna. And that experience will lead you to take new paths; consider new ideas.

There is an upside for an interior antenna that is pretty significant: If you love to fiddle with antennas, the attic provides a great environment because you don't need to be worried about the weather, and you can work on your antennas when your friends are "grounded" due to weather! You'll really appreciate that fact when wind or ice storms strike.

## **Questions and Answers**

- **Isn't the performance of an HF attic antenna always inferior to that of an outdoor**

## **antenna?**

Not necessarily. I've seen HF dipoles in attics outperform outdoor dipoles because the attic antennas had a height advantage. If the concern is attenuation caused by wood roofs and asphalt or slate shingles, you should know that at HF frequencies the impact is insignificant.

On the other hand, if the attic antenna is a compromise, compact design, it will almost always underperform a full-sized outdoor antenna (unless your attic is atop a 20-story building!).

- **Aren't the interference problems caused by attic antennas insurmountable?**

Not at all. There are a few problem areas for the HF attic antenna farmer, and RFI in the house is indeed one. Fortunately, these issues are not as serious as they may seem, especially with so much modern consumer technology shifting to VHF and microwave spectrum for communication (the typical consumer Wi-Fi computer network operates at 2.4 GHz).

That said, interference can become an issue if you insist on using higher power levels (50 W and up). The good news is that most problems can be easily remedied with the application of ferrite chokes on the afflicted devices (usually telephones or televisions). Pick up a copy of the *ARRL RFI Book* and keep it on hand as your reference for diagnosis and treatment.

- **Won't the RF energy radiated by an attic antenna be dangerous to the people in the house?**

At HF frequencies – even with substantial RF power output — the exposure level for the inhabitants of your home will be well below the permitted threshold. There is much more detail on this subject in Chapter 4.

- **Are attic antennas fire hazards?**

In most instances, no.

For the most common type of HF antenna, the dipole, the high voltage points are at the ends of the antenna. The conductivity of open air is roughly  $0.3$  to  $0.8 \times 10^{-14}$  Siemens per Meter. That is a very poor degree of conductivity, so it requires a large amount of electrical energy to create a spark across a one-inch gap.

But a spark to where? Critics fail to consider that electricity can only flow when it has a path to ground. The end of an antenna may be at a high voltage potential, but to where is that spark going to jump? Dry wood has an extremely high resistance value, so even with a bare wire connected directly to wood, the resistance in the return path to ground is essentially infinite. Current won't flow, and the wood won't heat to the point of combustion.

Now this is not a free pass to ignore good engineering and safety practices. And to the extent local regulations or perhaps insurance company considerations exist, you may be required to expand your precautions.

When building attic antennas, we often want to keep the wires away from the wood structure, especially at the ends, because of the capacitive detuning effects. This is good antenna building logic and it gives you some additional piece of mind should you ever attempt to run high power levels with your attic installation. Also keep your antenna wires away from any metal pipes, duct work or electrical wiring that may be in your attic.

- **Aren't attics awfully hot environments in which to work on antennas?**

Well, yes, they can be. If you need to be told "Don't climb your outside tower in an ice storm," you should also appreciate the advice "Don't build attic antennas in the heat of the summer." Common sense applies here. If you must work in your attic during the summer, do it in the early morning or at night.

- **By working in my attic, don't I run the risk of falling?**

Yes, that can happen. In most cases, the injuries will be more to your dignity and bank account. Attic antenna farming requires the ability to negotiate rafters and keep your feet on the floor joists. If you slip and fall, your foot will easily go through the sheetrock ceiling. If you aren't sufficiently nimble, find someone else to do it.

- **What if my house has a metal roof and is covered with wire-impregnated stucco on the sides?**

Okay. I give up on that one!



**Foil-backed insulation is the bane of any indoor antenna installation. If the roof of your attic is insulated with this material, you won't be able to install an antenna in that space.**

But having said all that, a shared attic is still an excellent place for an antenna. At the very least, you could install a commercial antenna such as a Bilal Isotron, a remotely adjustable mobile antenna (in a horizontal orientation, perhaps) or even a magnetic loop antenna (assuming you can get it through the hatch and into the attic). Of course, a long wire antenna is still possible in a shared attic if you are careful and considerate.

Before you start planting antennas in your attic, take a look around. Check the underside of the roof in particular. Is the underside packed with insulation? If the answer is “yes,” gently pull down a small corner of the insulating material and see what is on the other side. Some types of insulation have a metal backing and, for obvious reasons, this is not a good situation for antennas. You may decide to remove such insulation, but it may have a strong negative impact on your utility bills. And if you're a renter, your landlord may be displeased if he or she finds out.

It pays to take a glance at your roof from the outside as well. You don't have to scale a ladder, but take a good look from ground level and see if you can determine whether the roof is overlaid with asphalt shingles or something similar. If your attic space is under a metal roof, that's bad news because it renders your attic unusable as an antenna farm.

Assuming that you can use your attic, what's the best antenna to put up there? The answer is

easy: the largest antenna that will fit the space. Even if you have a relatively small attic, chances are good that you can install the same wire dipole or loop that you would use indoors. For example, I have used remote automatic antenna tuners in attics with good success. In one townhouse attic, I installed a small wire loop antenna in the 20 × 20 foot attic, stringing the wires along the rafters and holding them in place with nylon string (see **Figure 2.8**). At the feed point, I ran a 6-foot length of ladder line to a remote automatic antenna tuner. From the antenna tuner, I snaked 30 feet of RG-58 coaxial cable all the way back to my radio. With this arrangement, I was able to operate on 30 through 10 meters.

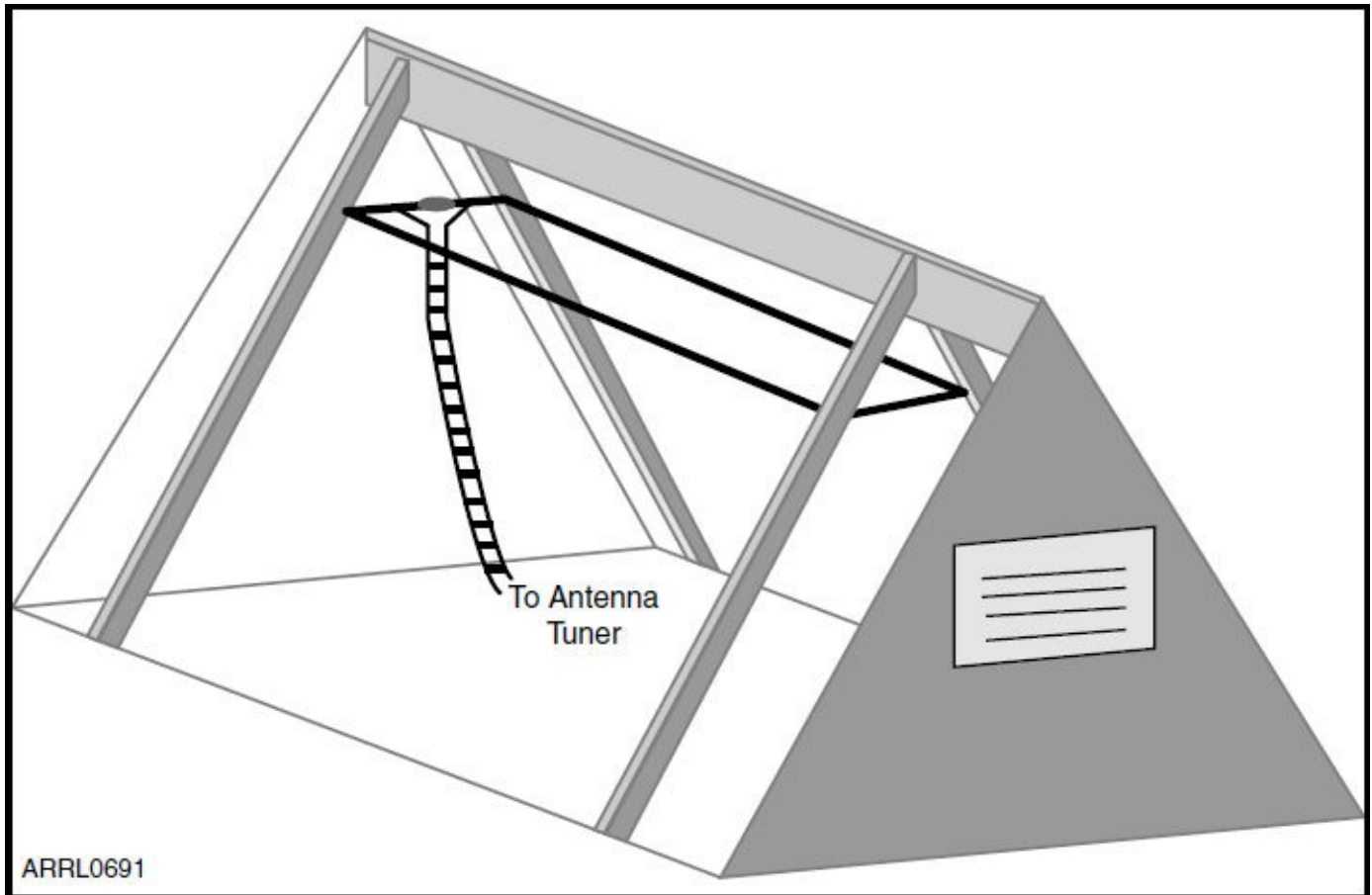

**Figure 2.8 – An HF loop antenna can be easily installed within an attic by stringing the wire along the rafters. You can feed it with 450  $\Omega$  ladder line and use an antenna tuner for multiband operation.**

Depending on the size and the design of your attic, you can do some amazingly creative things. For instance, let's say that you have a sizable attic in a house with wood or vinyl siding. It is possible to use such an attic to install a wire Yagi antenna for 20 meters or the higher bands by draping wires for the antenna element along the rafters. See **Figure 2.9**. To be sure, this would be a challenging antenna design. You would have to do quite a bit of trimming and repositioning of wires to finally achieve the best result. And it goes without saying that this antenna would have a fixed pattern since you wouldn't be able to rotate it. Even so, a large directional antenna can be built within an attic, and it will work quite well. I once installed an antenna like this for the 10-meter band while I was living in a condominium with a relatively small attic. It took me all day, even with an antenna analyzer, to finally get all the wires in the

right places and the antenna adjusted for the lowest SWR, but DX stations within the pattern of my antenna reported that I often had an impressive signal while running just 25 W.

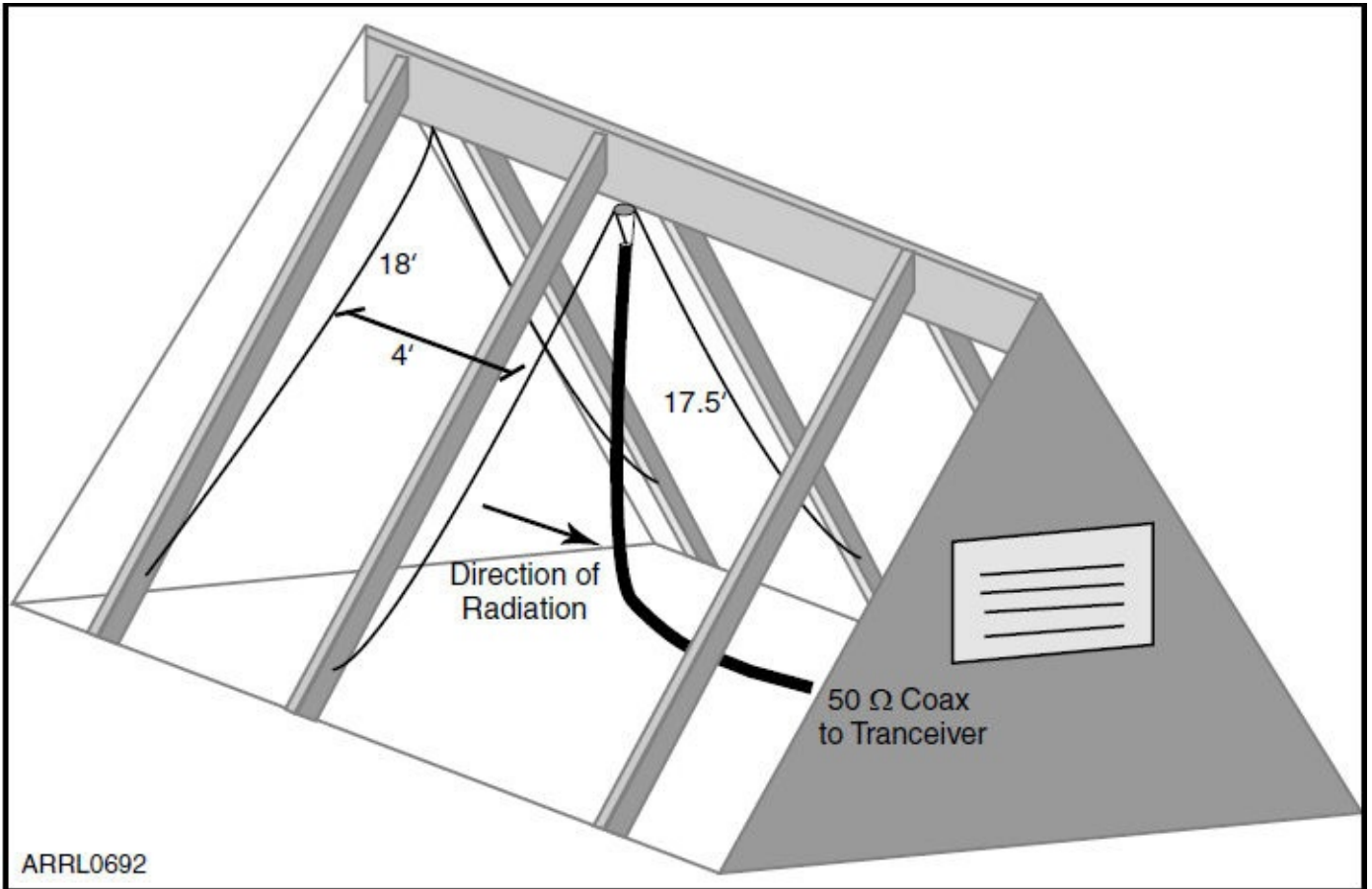

**Figure 2.9 – If you have a sufficiently large attic, you can even construct a wire Yagi antenna by using rafters as supports. This example is a 10-meter version. Dimensions shown are approximate.**

# Dealing With Interference

As an indoor amateur, there are two types of interference you are likely to encounter: (1) Interference you inflict upon yourself and your neighbors and (2) interference that your consumer electronic devices, and those of your neighbors, *inflict upon you*.

The good news is that there are steps you can take to mitigate the interference you may encounter (or generate!). The first step is to get a better understanding of the true nature of radio frequency interference, otherwise known as RFI.

There are four basic types of RFI that apply to Amateur Radio.

**(1) Fundamental Overload** — Disruption or degradation of a device's function in the presence of a transmitter's fundamental signal (the intended signal from the transmitter).

**(2) Spurious Emissions** — When reception of a radio signal is interfered with by spurious emissions from a transmitter.

**(3) External Noise Sources** — When reception of a radio signal is interfered with by RF energy transmitted incidentally or unintentionally by a device that is not a licensed transmitter. This is a device in your home or your neighbor's home.

**(4) Intermodulation** — When reception of a radio signal is interfered with by intermodulation distortion (IMD) products generated inside or outside of the receiver.

As an RFI troubleshooter, it is helpful to start by determining which of these is involved in your interference problem. Once you know the type of RFI, selecting the most appropriate cure for the problem becomes much easier.

In an indoor operation, most cases of interference caused by an amateur transmission — *those that you cause* — are due to fundamental overload. In an ideal world, any properly designed radio receiver should be able to select the desired signal, while rejecting all others. Unfortunately, because of design deficiencies such as inadequate shields or filters, some radio receivers are unable to reject strong out-of-band signals. Electronic equipment that is not a radio receiver (audio amplifiers and speakers come to mind) can also suffer from fundamental overload from similar design shortcomings.

You are less likely to encounter interference caused by spurious emissions. All transmitters generate some (hopefully few) RF signals that are outside their intended transmission bandwidth. Out-of-band signals result from distortion in the modulation process, or consist of broadband noise generated by the transmitter's oscillators that is added to the intended signal. Harmonics, the most common spurious emissions, are signals at integer multiples of the operating (or fundamental) frequency. Unless your neighbor is also operating an Amateur Radio station, the odds of you being plagued by this type of interference are low.

When it comes to interference *to your station*, almost all of these problems will be due to



external noise sources. Noise, in this sense, means an RF signal that is not essential to the generating device's operation. The most common external noise sources are electrical, primarily power lines. Motors and switching equipment can also generate electrical noise. Your neighbor's washing machine, for example, can be a strong source of electrical noise.

External noise can also come from unlicensed so-called "Part 15" devices. (Part 15 is a reference to the FCC rules and regulations that govern unlicensed transmitters). In our increasingly wireless world, these devices are everywhere. They can be computers, video games, appliances and other types of consumer electronics. They are in your home and in the homes of your neighbors, so it is almost a certainty that you will run into at least some of these Part 15 signals.

Finally, similar to interference caused by spurious emissions, problems caused by intermodulation distortion (IMD) are uncommon in indoor installations. Intermodulation distortion is caused by two signals combining in such a way as to create *intermodulation products* — signals at various combinations of the two original frequencies. The two original signals may be perfectly legal, but the resulting *intermodulation distortion products* may occur on the frequencies used by other signals and cause interference in the same way as a spurious signal from a transmitter. Depending on the nature of the generating signals, "intermod" can be intermittent or continuous. IMD can be generated inside a receiver by large signals or externally by signals mixing together in non-linear junctions or connections.

## Identifying the Type of RFI Source

It is useful to place an offending noise source into one of several broad categories at the early stages of any RFI investigation. Because locating and resolution techniques can vary somewhat for each type, the process of locating and resolving RFI problems should begin with identifying the general type of RFI source.

It is often impossible to identify the exact type of device generating the RFI from the sound of the interference. Because there are many potential sources of RFI, it is often more important to obtain and interpret clues from the general noise characteristics and the patterns in which it appears.

A source that exhibits a repeatable pattern during the course of a day or week, for example, suggests something associated with human activity. A sound that varies with, or is affected by, weather suggests an outdoor source. Noise that occurs in a regular and repeating pattern of peaks and nulls as you tune across the spectrum, every 50 kHz for example, is often associated with switchmode power supplies or similar pulsed-current devices. A source that exhibits fading or other sky-wave characteristics suggests something that is not local. A good ear and careful attention to detail will often turn up some important clues. A detailed RFI log can often help, especially if maintained over time.

Noise can be characterized as broadband or narrowband — another important clue. *Broadband noise* is defined as noise having a bandwidth much greater than the affected receiver's operating bandwidth and is reasonably uniform across a wide frequency range.

Noise from arcs and sparks, such as power-line noise, tend to be broadband. *Narrowband noise* is defined as noise having a bandwidth less than the affected receiver's bandwidth. Narrowband noise is present on specific, discrete frequencies or groups of frequencies, with or without additional modulation. In other words, if you listened to the noise on an SSB receiver, tuning would cause its sound to vary, just like a regular signal. Narrowband noise often sounds like an unmodulated carrier with a frequency that may drift or suddenly change. Microprocessor clock harmonics, oscillators and transmitter harmonics are all examples of narrowband noise.

## Identifying Noise from Part 15 Devices

As I mentioned earlier, Part 15 devices and other consumer equipment noise sources are ubiquitous. Although the absolute signal level from an individual noise source may be small, their increasing numbers makes this type of noise a serious problem for indoor Amateur Radio stations.

Electronic devices containing oscillators, microprocessors or digital circuitry produce RF signals as a byproduct of their operation. The RF noise they produce may be radiated from internal wiring as a result of poor shielding. The noise may also be conducted to external, unshielded or improperly shielded wiring as a common-mode signal where it radiates noise. Noise from these devices is usually narrowband that changes characteristics (frequency, modulation, on-off pattern) as the device is used in different ways.

Another major class of noise source is equipment or systems that control or switch large currents. Among them are variable-speed motors in products as diverse as washing machines, elevators, and heating and cooling systems. Charging regulators and control circuitry for battery and solar power systems are a prolific source of RF noise, as are switchmode power supplies for computers and low-voltage lighting. This type of noise is only present when the equipment is operating.

Switchmode supplies, solar controllers and inverters often produce noise signals every  $N$  kHz, with  $N$  typically being from 5 to 50 or more kHz, the frequency at which current is switched. This is different from noise produced by spark or arc sources that is uniform across a wide bandwidth. This pattern is often an important clue in distinguishing switching noise from power-line or electrical noise.

Wired computer networks radiate noise directly from their unshielded circuitry and from network and power supply cables. The noise takes two forms — broadband noise and modulated carriers at multiple frequencies within the amateur bands. As an example, Ethernet network interfaces often radiate signals heard on a receiver in CW mode. Each network interface uses its own clock, so if you have neighbors with networks, you'll hear a cluster of carriers around these frequencies,  $\pm 500$  Hz or so.

In cable TV systems, video signals are converted to RF across a wide spectrum and distributed by coaxial cable into the home. Some cable channels overlap with amateur bands, but the signals should be confined within the cable system. No system is perfect, and it is

common for a defective coax connection to allow leakage to and from the cable. When this happens, a receiver outside the cable will hear RF from the cable, and the TV receiver may experience interference from local transmissions.

## Locating Sources of RFI

Locating an offending device or noise source might sometimes seem like trying to find a needle in a haystack. With a little patience and know-how, it is often possible to find the source of a problem in relatively short order. RF detective work is often required, and some cases require a little more perseverance than others. In any case, armed with some background and technique, it is often easier to find an offending source than the first-time RFI investigator might expect.

Whenever an unknown source of interference becomes an issue, begin the process of identifying the source by verifying that the problem is external to your radio. Start by removing the antenna connection. If the noise disappears, the source is external to your radio, and you are ready to begin hunting for the noise source.

### Noise Sources Inside Your Home

Unless you live in an apartment or condominium, most RFI sources will be ultimately found inside your own home. Locating an in-house source of RFI is so simple that it makes sense to start an investigation by simply turning off your home's main circuit breaker, while listening to the noise with a battery-powered portable radio. (Don't forget that battery-powered equipment may also be a noise source — remove the batteries from consumer devices, as well.) If the noise goes away, you know the source is in your residence. After resetting the breaker, you can further isolate the source by turning off individual breakers one at a time. Once you know the source circuit, you can then unplug devices on that circuit to find it.

**Caution:** *Do not attempt to remove cartridge fuses or operate exposed or open-type disconnects if it is possible to make physical contact with exposed electrical circuits. Also, if you live in an apartment or condominium, make sure the circuits you are turning off are within your residence only.*

### Noise Sources Outside Your Home

It is often possible to locate a noise source outside your home with a minimum of equipment and effort. Because of Part 15's absolute emissions limits, most Part 15 noise sources are within a few hundred feet of your antenna.

Electrical noise sources in a home, such as an arcing thermostat or a noisy washing machine controller, can also be tracked down in the same way as noise from consumer electronic devices. Electrical noise from an incidental emitter, such as a power line, can propagate much farther than noise from an otherwise legal unintentional emitter. Some Part 15 devices, battery chargers for electric scooters and wheelchairs, for example, are notorious for exceeding Part

15 absolute emissions limits on conducted noise.

The following procedures are intended for areas with detached houses rather than apartment or condominium units. However, you can adapt them accordingly.

One word of warning: We live in a time when people are particularly wary of the activities of strangers, especially strangers snooping around with radios. If your neighbors see you acting in a way they think is suspect, there is a probability that you may find yourself face to face with a police officer. While hunting interference outside your home, be friendly and forthcoming with information if approached. If you are a parent, invite your child along. Adults with children are seen as less threatening. Alternatively, if you own a friendly dog, take him for a walk with you. A dog on a leash will defuse many concerns.

Never walk onto someone's property and begin probing around their residence without permission – even if you strongly suspect that the interference culprit is inside their home. Once again, this approach is likely to result in a 911 call, or worse!

As you stroll casually along the street or sidewalk, use a detector suitable for receiving the noise, typically a battery-powered receiver. Preferably, the receiver should have a variable RF gain control. An external step attenuator will also work if the antenna is external to the radio. If the antenna can be removed, a probe can also be made from a small piece of wire or paperclip to reduce the receiver's sensitivity.

Once you identify the source residence and make the decision to approach your neighbor, the importance of personal diplomacy simply cannot be overstated. The first contact regarding an RFI problem between a ham and a neighbor is often the most important; it is the start of all future relations between the parties. The way you react and behave when you first discuss the problem can set the tone for everything that follows. It is important, therefore, to use a diplomatic path from the very start.

Greet your neighbor with a radio in hand, preferably an ordinary AM broadcast or short-wave receiver. Let them hear the noise, but not so loud that it will be offensive. Tell them this is the problem you are experiencing, and you believe the source may be in their home. Don't suggest what you think the cause is. If you're wrong, it often makes matters worse. Tell them it will only take a minute to determine whether the source is in their home. Most neighbors will agree to help find the source, and if they agree to turn off circuit breakers, it can be found very quickly. Start with the main breaker to verify you have the correct residence, then the individual breakers to find the circuit.

## **Interference Fixes**

Regardless of whether your interference problem is located in your home or a neighbor's home, there are a number of steps you can take to either cure the problem completely, or at least reduce the severity. If your transmissions are causing interference, the easy first step is to reduce your output power. As we discussed in Chapter 1, I strongly recommend low-power operation for the indoor ham. At the very least, if you are attempting to operate at the 100 W output level, consider reducing your output to 50 W. You'll notice little change in your ability

to make contacts, but you may see a major change in the severity of the interference you are causing.

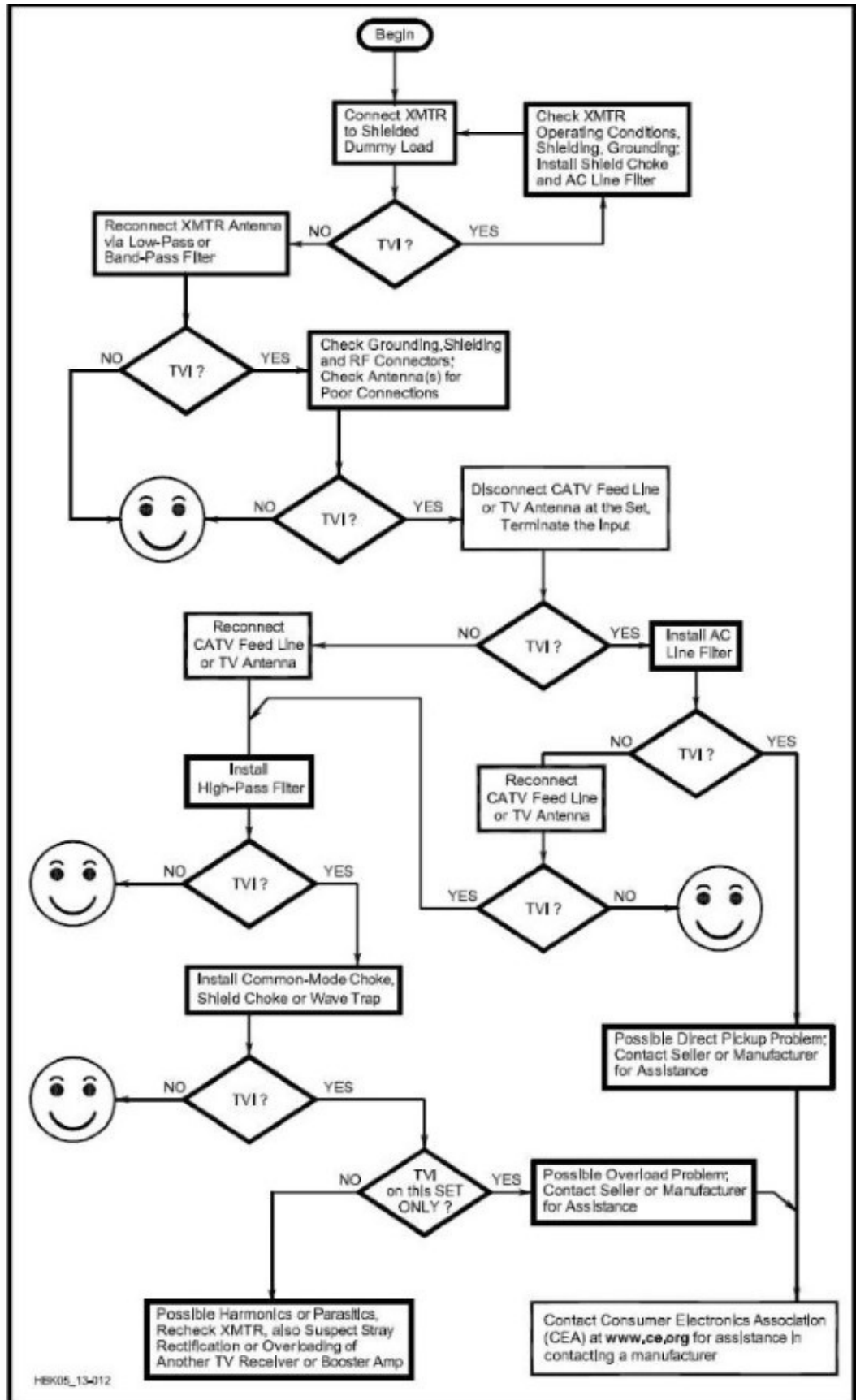

You can use this chart to help troubleshoot interference to a cable TV system.

HBK05\_13-012

## Filters and Chokes

Filters and chokes can be very effective in dealing with interference problems. Use of common-mode chokes alone can often solve many RFI issues, especially at HF when common-mode current is more likely to be the culprit.

A primary means of separating signals relies on their frequency difference. Filters offer little opposition to signals with certain frequencies while blocking or shunting others. Filters vary in attenuation characteristics, frequency characteristics and power-handling capabilities. The names given to various filters are based on their uses.

**Low-pass filters** pass frequencies below some cutoff frequency, while attenuating frequencies above that cutoff frequency. These filters are difficult to construct properly, so you should buy one. Many retail Amateur Radio stores that advertise in QST magazine stock low-pass filters.

**High-pass filters** pass frequencies above some cutoff frequency while attenuating frequencies below that cutoff frequency. Again, it is best to buy one of the commercially available filters.

**Bypass capacitors** can be used to cure RFI problems by providing a low-impedance path for RF signals away from the affected lead or cable. A bypass capacitor is usually placed between a signal or power lead and the equipment chassis. If the bypass capacitor is attached to a shielded cable, the shield should also be connected to the chassis. Bypass capacitors for HF signals are usually 0.01  $\mu\text{F}$ , while VHF bypass capacitors are usually 0.001  $\mu\text{F}$ . Leads of bypass capacitors should be kept short, particularly when dealing with VHF or UHF signals.

**AC-line filters**, sometimes called “brute-force” filters, are used to remove RF energy from ac power lines. Products from TE Connectivity, ([www.te.com/usa-en/products/emi-filters.html](http://www.te.com/usa-en/products/emi-filters.html)) and others are widely available.

AC-line filters come in a wide variety of sizes, current ratings, and attenuation. In general, a filter must be physically larger to handle higher currents at lower frequencies. The Corcom 1VB1, a compact filter small enough to fit in the junction box for many low-voltage lighting fixtures, provides good common mode attenuation at MF and HF, and its 1 A at 250 V ac rating is sufficient for many LV lighting fixtures. In general, you will get more performance from a filter that is physically small if you choose the filter with the lowest current rating sufficient for your application.

Any wiring between a filter and the equipment being filtered acts as an antenna and forms an inductive loop that degrades the performance of the filter. All such wiring should be as short as possible, and should be twisted. Always bond the enclosure of the filter to the enclosure of the equipment by the shortest possible path. Some commercial filters are built with an integral IEC power socket, and can replace a standard IEC connector if there is sufficient space behind the panel. (IEC is the International Electrotechnical Commission, an international standards organization that has created specifications for power plugs and sockets.) Such a filter is bonded to the chassis, and interconnecting leads are shielded by the chassis, optimizing its performance.

Typical behavior of common-mode and differential-mode current. The drawing in (A) shows the currents of a differential-mode signal, while (B) shows a common-mode signal with current flowing on all wires. That's why it is called "common" mode – it is common to all wires. In (C), a common-mode signal flows on the outside of a coaxial cable shield with a differential-mode signal inside the cable. In (D) the differential-mode signal flows on the internal wires, while a common-mode signal flows on the outside of the cable shield.

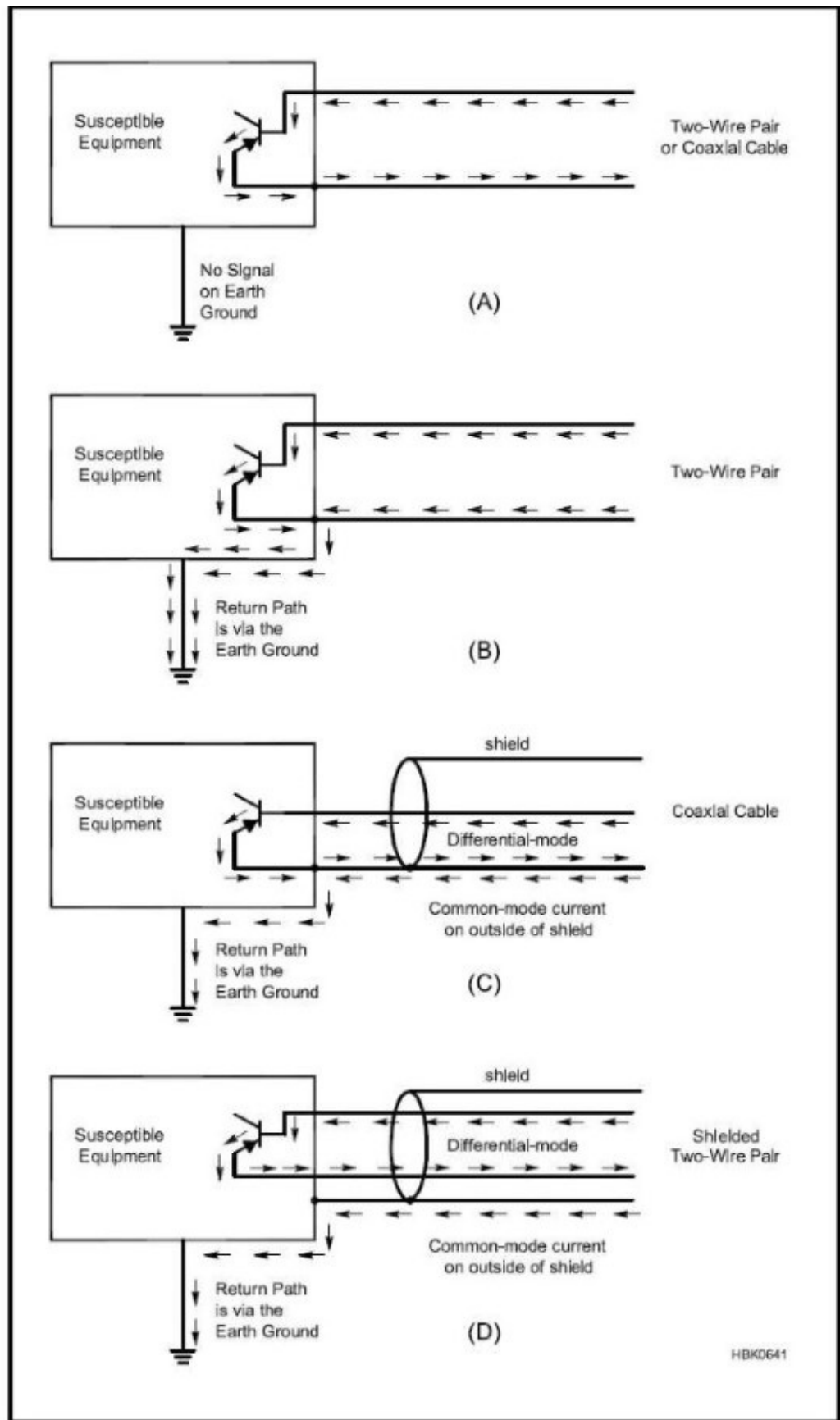

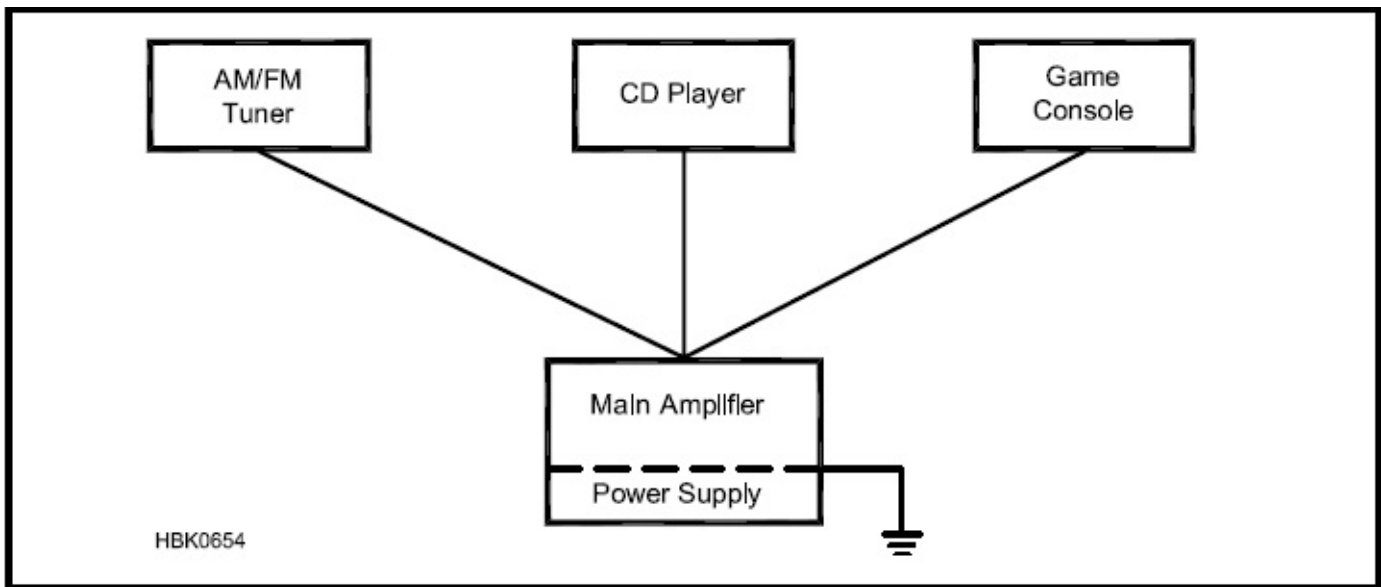

A single-point or “star” ground eliminates ground loops in an entertainment system with several components.

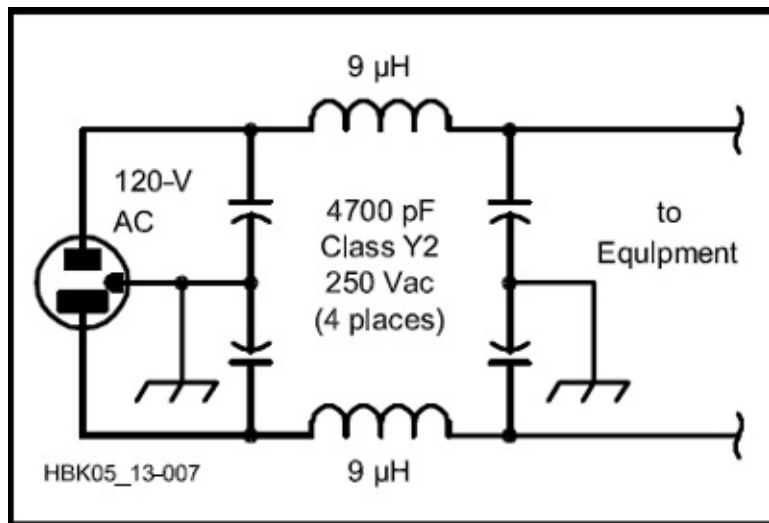

A “brute-force” ac line filter.

## Common-Mode Chokes

Common-mode chokes on ferrite cores are among the most effective answers to RFI from a common-mode signal. Common-mode chokes work differently, but equally well, with coaxial cable and paired conductors.

The most common form of common-mode choke is multiple turns of cable wound on a magnetic toroid core, usually ferrite. Most of the time, a common-mode signal on a coaxial cable or a shielded, multi-wire cable is a current flowing on the outside of the cable’s shield. By wrapping the cable around a magnetic core, the current creates a flux in the core, creating a high impedance in series with the outside of the shield. (An impedance of a few hundred to several thousand ohms are required for an effective choke.) The impedance then blocks or reduces the common-mode current. Because equal-and-opposite fields are coupled to the core from each of the differential-mode currents, the common-mode choke has no effect on signals



inside the cable.

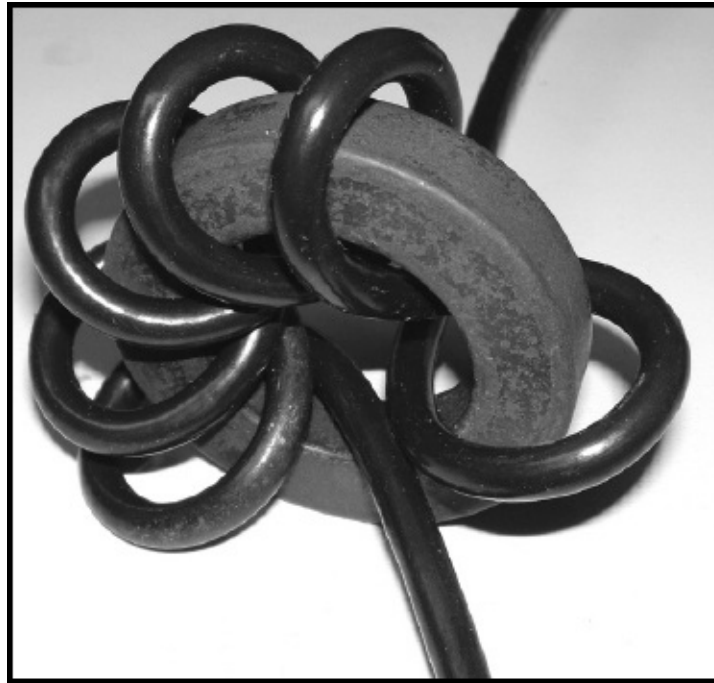

**An example of a common-mode choke made by winding coaxial cable through a 2-inch ferrite toroid.**

When the cable consists of two-wire, unshielded conductors such as zip cord or twisted-pair, the equal-and-opposite differential currents each create a magnetic flux in the core. The equal-and-opposite fluxes cancel each other and the differential-mode signal experiences zero net effect. To common-mode signals, however, the choke appears as a high impedance in series with the signal: the higher the impedance, the lower the common-mode current.

It is important to note that common-mode currents on a transmission line will result in radiation of a signal from the feed line. The radiated signal can then cause RFI in nearby circuits. This is most common when using coaxial cable as a feed line to a balanced load, such as a dipole antenna. Using a common-mode choke to reduce common-mode feed line currents can reduce RFI caused by signals radiated from the feed line's shield.

The optimum core size and ferrite material is determined by the application and frequency. For example, an ac cord with a plug attached cannot be easily wrapped on a small ferrite core. The characteristics of ferrite materials vary with frequency. Type 31 material is a good all-purpose material for HF and low-VHF applications, especially at low-HF frequencies. Type 43 is widely used for HF through VHF and UHF.

You'll often run into clamp-on split cores. These are essentially single-turn chokes as the cable passes just once through the bead or core. Multi-turn chokes are required for effective suppression at HF. It is usually more effective to form a common-mode choke by wrapping about multiple turns of wire or coaxial cable around a 1- to 2-inch OD core of the correct material. Otherwise, you'd have to clamp quite a few cores on a cable that you think is causing (or being subjected to) RFI.

## Specific Fixes

**DVD and Video Players:** A DVD, or similar video player, usually contains a television tuner or has a TV channel output. It is also connected to an antenna or cable system and the ac line, so it is subject to all of the interference problems of a TV receiver. Start by proving that the video player is the susceptible device. Temporarily disconnect the device from the television or video monitor. If there is no interference to the TV, then the video player is the most likely culprit.

Next, find out how the interfering signal is getting into the video player. Temporarily disconnect the antenna or cable feed line from the video player. If the interference goes away, then the antenna line is involved. In this case, you can probably fix the problem with a common-mode choke or high-pass filter.

**Telephones:** Telephones have probably become the number one, non-TV interference problem of Amateur Radio. However, most cases of telephone interference can be cured by correcting any installation defects and installing telephone RFI filters where needed.

Telephones can improperly function as radio receivers. Semiconductor devices inside many telephones act like diodes. When such a telephone is connected to the telephone wiring (a large antenna) an AM radio receiver can be formed. When a nearby transmitter goes on the air, these telephones can be affected.

Troubleshooting techniques were discussed earlier in the chapter. Start by simplifying the problem. Disconnect all telephones except one, right at the service entrance if possible, and start troubleshooting the problem there.

If any single device or bad connection in the phone system detects RF and puts the detected signal back onto the phone line as audio, that audio cannot be removed with filters. Once the RF has been detected and turned into audio, it cannot be filtered out because the interference is at the same frequency as the desired audio signal. To effect a cure, you must locate the detection point and correct the problem there.

Defective telephone company lightning arrestors can act like diodes, rectifying any nearby RF energy. Telephone-line amplifiers or other electronic equipment may also be at fault. Do not attempt to diagnose or repair any telephone company wiring or devices on the “telco” side of your service box or that were installed by the phone company. Request a service call from your phone company.

Inspect the telephone system installation. Years of exposure in damp basements, walls or crawl spaces may have caused deterioration. Be suspicious of anything that is corroded or discolored. In many cases, homeowners have installed their own telephone wiring, often using substandard wiring. If you find sections of telephone wiring made from nonstandard cable, replace it with standard twisted-pair telephone or CAT5 cable. If you do use telephone cable, be sure it is high-quality twisted-pair to minimize differential-mode pickup of RF signals.

Next, evaluate each of the telephone instruments. If you find a susceptible telephone, install a telephone RFI filter on that telephone, such as those sold by K-Y Filters ([www.ky-filters.com](http://www.ky-filters.com)). If the home uses a DSL broadband data service, be sure that the filters do not affect DSL performance by testing online data rates with and without a filter installed at the telephone instrument.

If you determine that you have interference only when you operate on one particular ham band, the telephone wiring is probably resonant on that band. Install common-mode chokes on the wiring to add a high impedance in series with the “antenna.”

**Telephone Accessories:** Answering machines are also prone to interference problems. All of the troubleshooting techniques and cures that apply to telephones also apply to these telephone devices. In addition, many of these devices connect to the ac mains. Try a common-mode choke and/or ac-line filter on the power cord (which may be an ac cord set, a small transformer or power supply).

**Cordless Telephones:** A cordless telephone is an unlicensed *radio* device that is manufactured and used under Part 15 of the FCC regulations. The FCC does not intend Part 15 devices to be protected from interference. These devices usually have receivers with very wide front-end filters, which make them very susceptible to interference.

A likely path for interference to cordless phones is as common-mode current on the base unit’s connecting cables that will respond to common-mode chokes. In addition, a telephone filter on the base unit and an ac-line filter may help. The best source of help is the manufacturer, but they may point out that the Part 15 device is not protected from interference.

**Audio Equipment:** Consumer and commercial audio equipment, such as stereos, home entertainment systems, intercoms and public-address systems, can also pick up and detect strong nearby transmitters. The RFI can be caused by one of several things: pickup on speaker leads or interconnecting cables, pickup by the ac mains wiring or direct pickup. If the interference involves wiring connected to the affected device, common-mode chokes are the most likely solution.

Use the standard troubleshooting techniques discussed earlier in this chapter to isolate problems. In a multi-component home entertainment system, for example, you must determine what combination of components is involved with the problem. First, disconnect all auxiliary components to determine if there is a problem with the main receiver/amplifier. Long speaker or interconnect cables are prime suspects.

**Stereos and Home Entertainment Systems:** If the problem remains with the main amplifier isolated, determine if the interference level is affected by the volume control. If so, the interference is getting into the circuit *before* the volume control, usually through accessory wiring. If the volume control has no effect on the level of the interfering sound, the interference is getting in *after* the control, usually through speaker wires.

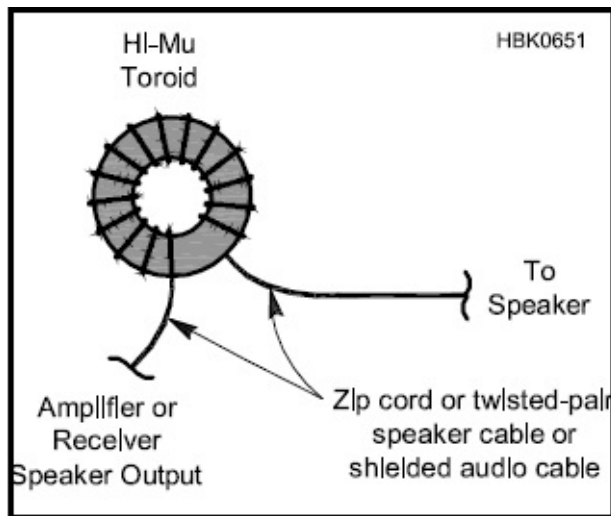

**Making a common-mode choke for a speaker.**

Speaker wires are often effective antennas on HF. The speaker terminals are often connected directly to the output amplifier transistors. Modern amplifier designs use a negative feedback loop to improve fidelity. This loop can conduct the detected RF signal back to the high-gain stages of the amplifier. The combination of all of these factors often makes the speaker cables the dominant receiving antenna for RFI.

*There is a simple test that will help determine if the interfering signal is being coupled into the amplifier by the speaker leads.* Temporarily disconnect the speaker leads from the amplifier, and plug in a test set of headphones with short leads. If there is no interference with the headphones, filtering the speaker leads will likely cure the problem.

Start by applying common-mode chokes. Wrap the speaker wires around a large (2-inch or larger) ferrite core to cure speaker-lead RFI. Type 31 material is preferred at HF.

In some cases, the speaker wires may be picking up RF as a differential-mode signal. To reduce differential-mode pickup, replace the zip cord speaker wire with twisted-pair wire. (#16 AWG will work for most systems with higher-power systems requiring #12 AWG.)

**Powered Speakers:** A powered speaker is one that has its own built-in power amplifier. Powered subwoofers are common in home entertainment systems and small powered speakers are often used with computer and gaming systems. If a speaker runs on batteries and/or an external power supply, or is plugged into the mains power, it is a powered loudspeaker. Powered loudspeakers are notoriously susceptible to common-mode interference from internally misconnected cable shields and poor shielding. Apply suitable common-mode chokes to all wiring, including power wiring. Unshielded speakers may not be curable, however.

**Computers:** Computers and other microprocessor-based devices can be sources or victims of interference. These devices contain oscillators that can, and do, radiate RF energy. In addition, the internal functions of a computer generate different frequencies, based on the various data signals. All of these signals are digital — with fast rise and fall times that are rich in harmonics.

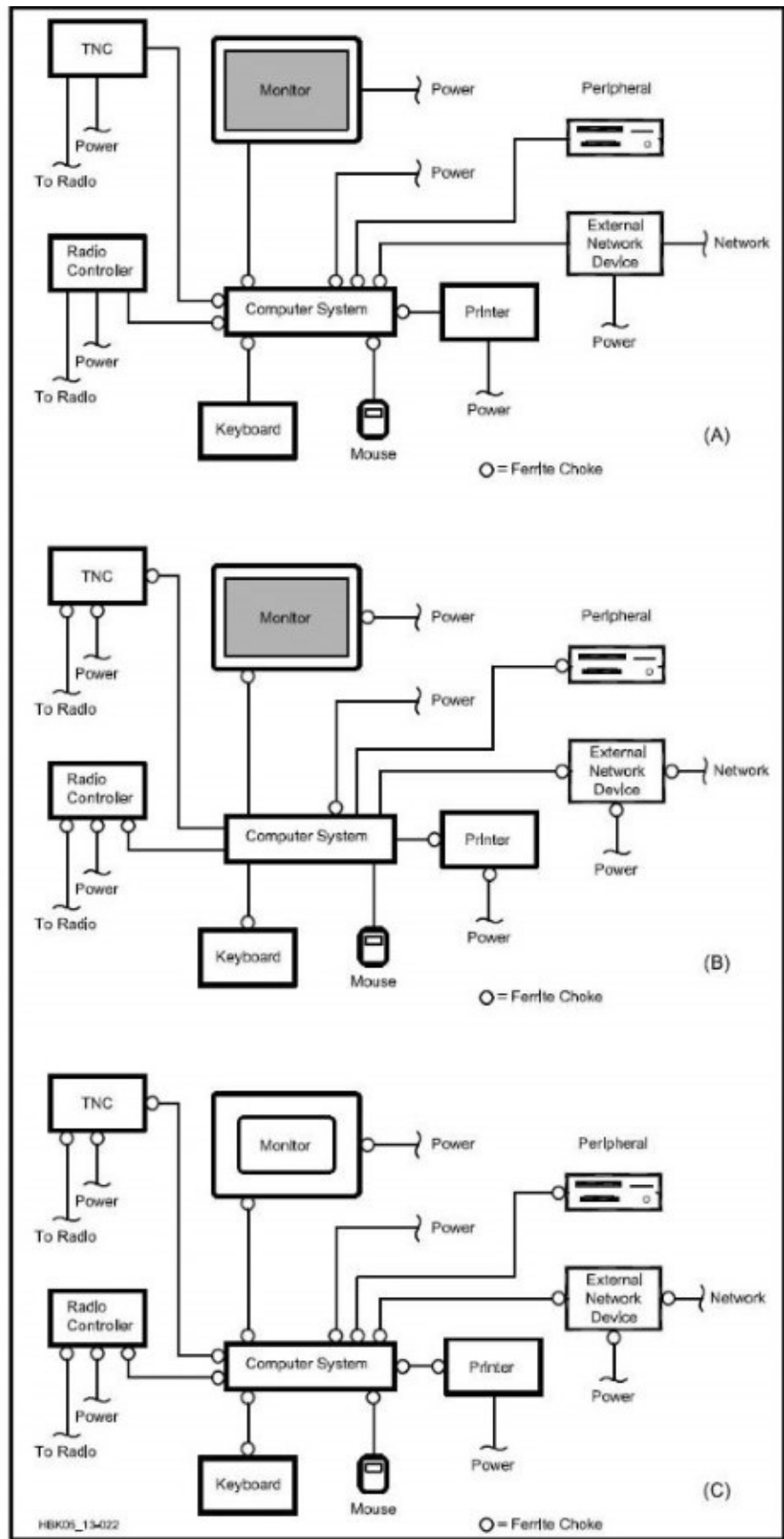

Here are guidelines for installing ferrite chokes on a “noisy” computer system. At (A), the computer is noisy, but the peripheral devices are quiet. At (B), the computer is quiet, but the external devices are noisy. At (C), you have the worst case, where every device is generating RF noise.

HEK05\_134022

Computing devices are covered under Part 15 of the FCC regulations as unintentional emitters. As for any other unintentional emitter, the FCC has set absolute radiation limits for these devices. As previously discussed in this chapter, FCC regulations state that the operator or owner of Part 15 devices must take whatever steps are necessary to reduce or eliminate any

interference they cause to a licensed radio service. This means that if your neighbor's video game interferes with your radio, the neighbor is responsible for correcting the problem. (Of course, your neighbor may appreciate your help in locating a solution!)

The FCC has set up two tiers of limits for computing devices. Class A is for computers used in a commercial environment. FCC Class B requirements are more stringent — for computers used in residential environments. If you buy a computer or peripheral, *be sure that it is Class B certified*, or it will probably generate interference to your amateur station or home-electronics equipment.

If you find that your computer system is interfering with your radio (not uncommon in this digital-radio age), start by simplifying the problem. Temporarily remove power from as many peripheral devices as possible and disconnect their cables from the computer. (It is necessary to physically remove the power cable from the device, because many devices remain in a low-power state when turned off from the front panel or by a software command.) If possible, use just the computer, keyboard and monitor. This test may identify specific peripherals as the source of the interference.

Ensure that all peripheral connecting cables are shielded. Replace any unshielded cables with shielded ones; this often significantly reduces RF noise from computer systems. The second line of defense is the common-mode choke. The choke should be installed as close to the computer and/or peripheral device as practical.

Switchmode power supplies in computers are often sources of interference. A common-mode choke and/or ac-line filter may cure this problem. In extreme cases of computer interference, you may need to improve the shielding of the computer. (Refer to the *ARRL RFI Book* for more information about this.)

# RF Safety

Operating an Amateur Radio station indoors means that you, your family and your neighbors are likely to find themselves in proximity to RF energy. This does not mean that any of you are necessarily at risk from that energy. After all, modern humans are bathed in RF energy on a daily basis; even the ac power lines in our homes radiate RF energy, albeit at a very low frequency.

The question of the safety of RF energy has been controversial, and science has yet to determine that a harmful relationship definitively exists between RF energy and human health. The exceptions apply to the most extreme instances where people have been exposed to very high power levels, usually at very high frequencies (microwave ovens come to mind).

Even so, FCC regulations set limits on the maximum permissible exposure (MPE) allowed from the operation of radio transmitters. Following these regulations, along with the use of good RF practices, will make your indoor station as safe as possible. In this chapter, I will go into some detail on the topic of RF safety, perhaps a bit more than is strictly necessary, but it is an important topic. You might even want to show some of this text to family or neighbors if they express concern. Much of what you will read was contributed by the ARRL RF Safety Committee.

## How Electromagnetic Fields Affect Us

All life on Earth has adapted to live in an environment of weak, natural, low-frequency electromagnetic fields, in addition to the Earth's static geomagnetic field. Natural low-frequency electromagnetic (EM) fields come from two main sources: the Sun and thunderstorm activity. During the past 100 years, man-made fields at much higher intensities and with different spectral distributions have altered our EM background. Researchers continue to look at the effects of RF exposure over a wide range of frequencies and levels.

Both RF and power-frequency fields are classified as *nonionizing radiation* because the frequency is too low for there to be enough photon energy to ionize atoms. *Ionizing radiation*, such as X-rays, gamma rays and some ultraviolet radiation, has enough energy to knock electrons loose from atoms. When this happens, positive and negative *ions* are formed. At sufficiently high power densities, nonionizing RF poses certain health hazards.

It has been known since the early days of radio that RF energy can cause injuries by heating body tissue. Anyone who has ever touched an improperly grounded radio chassis or energized antenna and received an *RF burn* will agree that this type of injury can be quite painful. Excessive RF heating of the male reproductive organs can cause sterility by damaging sperm.

Other health problems can also result from RF heating. These heat-related health hazards are called *thermal effects*. A microwave oven is an application that puts thermal effects to practical use.

There have also been observations of changes in physiological function in the presence of RF energy levels that are too low to cause heating. These functions generally return to normal when the field is removed. Although research is ongoing, no harmful health consequences have been linked to these changes.

In addition to the ongoing research, much more has been done to address this issue. For example, FCC regulations set limits on exposure from radio transmitters. The Institute of Electrical and Electronics Engineers, the American National Standards Institute and the National Council for Radiation Protection and Measurement, among others, have recommended voluntary guidelines to limit human exposure to RF energy. As mentioned earlier, the ARRL maintains an RF Safety Committee, consisting of concerned scientists and medical doctors, who volunteer to serve the radio amateur community to monitor scientific research and to recommend safe practices.

## Thermal Effects of RF Energy

Body tissues that are subjected to *very high* levels of RF energy may suffer serious heat damage. These effects depend on the frequency of the energy, the power density of the RF field that strikes the body and factors such as the polarization of the wave and the grounding of the body.

At frequencies near the body's natural resonances, RF energy is absorbed more efficiently. In adults, the primary resonance frequency is usually about 35 MHz if the person is grounded, and about 70 MHz if insulated from the ground. Various body parts are resonant at different frequencies. As a result, body size determines the frequency at which most RF energy is absorbed. As the frequency is moved farther from resonance, RF energy absorption becomes less efficient. *Specific absorption rate (SAR)* is a measure that takes variables such as resonance into account to describe the rate at which RF energy is absorbed in tissue, typically measured in watts per kilogram of tissue (W/kg).

*Maximum permissible exposure (MPE)* limits define the maximum electric and magnetic field strengths, and the plane-wave equivalent power densities associated with these fields, that a person may be exposed to without harmful effect, and are based on whole-body SAR safety levels. The safe exposure limits vary with frequency as the efficiency of absorption changes. The MPE limits and safety factors are included to insure that the MPE field strength will never result in an unsafe SAR.

Thermal effects of RF energy are usually not a major concern for most radio amateurs because the power levels normally used tend to be low, and the intermittent nature of most amateur transmissions decreases total exposure. Amateurs spend more time listening than transmitting and many amateur transmissions such as CW and SSB use low-duty-cycle modes. With FM or RTTY, though, the RF is present continuously at its maximum level during each



transmission. It is rare for radio amateurs to be subjected to RF fields strong enough to produce thermal effects, unless they are close to an energized antenna or unshielded power amplifier.

Biological effects resulting from exposure to power levels of RF energy that do not generate measurable heat are called *athermal effects*. A number of athermal effects of RF exposure on biological tissue have been seen in the laboratory. However, to date, all athermal effects that have been discovered have had the same features: they are transitory, or go away when the RF exposure is removed, and they have *not* been associated with any negative health effects.

## Researching Biological Effects of RF Exposure

This is where much of the public angst about RF safety comes into play. The statistical basis of scientific research that confuses many non-scientists is the inability of science to state unequivocally that RF is safe. Effects are studied by scientists using statistical inference where the “null hypothesis” assumes there is no effect and then tries to disprove this assumption by proving an “alternative hypothesis” that there is an effect. The alternative hypothesis can never be entirely disproved because a scientist cannot examine every possible case, so scientists only end up with a *probability* that the alternative hypothesis is *not* true. To be entirely truthful, a scientist can never say that something was proven; with respect to low-level RF exposure, no scientist can guarantee that it is absolutely safe. At best, science can only state that there is a very low probability that it is unsafe. While scientists accept this truism, many members of the general public who are suspicious of RF and its effects on humans see this as a reason to continue to be afraid.

There are two types of scientific study that are used to learn about the effects of RF exposure: laboratory and epidemiological.

## Laboratory Study

Scientists conduct laboratory research using animals to learn about biological mechanisms by which RF may affect mammals. The main advantage of laboratory studies on the biological effects of RF is that the exposures can be controlled very accurately.

Some major disadvantages of laboratory study also exist. RF exposure may not affect the species of animals used in the investigations the same way that humans may respond. A common example of this misdirection occurred with eye research. Rabbits had been used for many years to determine that exposure of the eyes to high levels of RF could cause cataracts. The extrapolation of these results to humans led to the fear that use of radio would harm one’s vision. However, the rabbit’s eye is on the surface of its skull, while the human eye is buried deep within the bony orbit in the skull. As a result, the human eye receives much less exposure from RF and is less likely to be damaged by the same exposures that had been used in the laboratory experiments on rabbits.

Some biological processes that affect tissue can take many years to occur and laboratory

experiments on animals tend to be of shorter duration, in part because the life spans of most animals are much shorter than that of humans. For instance, a typical laboratory rat can be studied at most for two years, during which it progresses from youth to old age with all of the attendant physiological changes that come from normal aging. A disease process that takes multiple exposures over many years to occur is unlikely to be seen in a laboratory study with small animals.

## Epidemiological Research

Epidemiologists look at the health patterns of large groups of people using statistical methods. In contrast to laboratory research, epidemiological research has very poor control of its subjects' exposures to RF, but it has the advantages of being able to analyze the effects of a lifetime of exposure and of being able to average out variations among large populations of subjects. By their basic design, epidemiological studies do not demonstrate cause-and-effect, nor do they postulate mechanisms of disease. Instead, epidemiologists look for associations between an environmental factor and an observed pattern of illness. Apparent associations are often seen in small preliminary studies that later are shown to have been incorrect. At best, such results are used to motivate more detailed epidemiological studies and laboratory studies that narrow down the search for cause-and-effect.

Some preliminary studies have suggested a *weak* association between exposure to RF at home or at work and various malignant conditions including leukemia and brain cancer. A larger number of equally well-designed and performed studies, however, have found no association. Risk ratios as high as 2 have been observed in some studies. This means that the number of observed cases of disease in the test group is up to 2 times the “expected” number in the population. Epidemiologists generally regard a risk ratio of 4 or greater to be indicative of a strong association between the cause-and-effect under study. For example, men who smoke one pack of cigarettes per day increase their risk for lung cancer tenfold compared to nonsmokers, and two packs per day increases the risk to more than 25 times the nonsmokers' risk.

Epidemiological research by itself is rarely conclusive, however. Epidemiology only identifies health patterns in groups — it does not ordinarily determine their cause. There are often confounding factors. Most of us are exposed to many different environmental hazards that may affect our health in various ways. Moreover, not all studies of persons likely to be exposed to high levels of RF have yielded the same results (see sidebar on preliminary epidemiological studies).

## Safe Exposure Levels

How much RF energy is safe? Scientists and regulators have devoted a great deal of effort to deciding upon safe RF-exposure limits. This is a very complex problem, involving difficult public health and economic considerations. The recommended safe levels have been revised

downward several times over the years — and not all scientific bodies agree on this question even today. The latest Institute of Electrical and Electronics Engineers (IEEE) C95.1 standard for recommended radio frequency exposure limits was published in 2006, updating one that had previously been published in 1991 and adopted by the American National Standards Institute (ANSI) in 1992. In the new standard, changes were made to better reflect the current research, especially related to the safety of cellular telephones. At some frequencies, the new standard determined that higher levels of exposure than previously thought are safe.

The IEEE C95.1 standard recommends frequency-dependent and time-dependent maximum permissible exposure levels. Unlike earlier versions of the standard, the 1991 and 2006 standards set different RF exposure limits in *controlled environments* (where energy levels can be accurately determined and everyone on the premises is aware of the presence of EM fields) and in *uncontrolled environments* (where energy levels are not known or where people may not be aware of the presence of EM fields). FCC regulations adopted these concepts to include controlled/occupational and uncontrolled/general population exposure limits.

The graph in **Figure 4.1** depicts the 1991 IEEE standard (which is still used as the basis of FCC regulation). It is necessarily a complex graph, because the standards differ not only for controlled and uncontrolled environments but also for electric (E) fields and magnetic (H) fields. Basically, the lowest E-field exposure limits occur at frequencies between 30 and 300 MHz. The lowest H-field exposure levels occur at 100-300 MHz. The ANSI standard sets the maximum E-field limits between 30 and 300 MHz at a power density of  $1 \text{ mW/cm}^2$  (61.4 V/m) in controlled environments — but at one-fifth that level ( $0.2 \text{ mW/cm}^2$  or 27.5 V/m) in uncontrolled environments. The H-field limit drops to  $1 \text{ mW/cm}^2$  (0.163 A/m) at 100-300 MHz in controlled environments and  $0.2 \text{ mW/cm}^2$  (0.0728 A/m) in uncontrolled environments. Higher power densities are permitted at frequencies below 30 MHz (below 100 MHz for H-fields) and above 300 MHz, based on the concept that the body will not be resonant at those frequencies and will, therefore, absorb less energy.

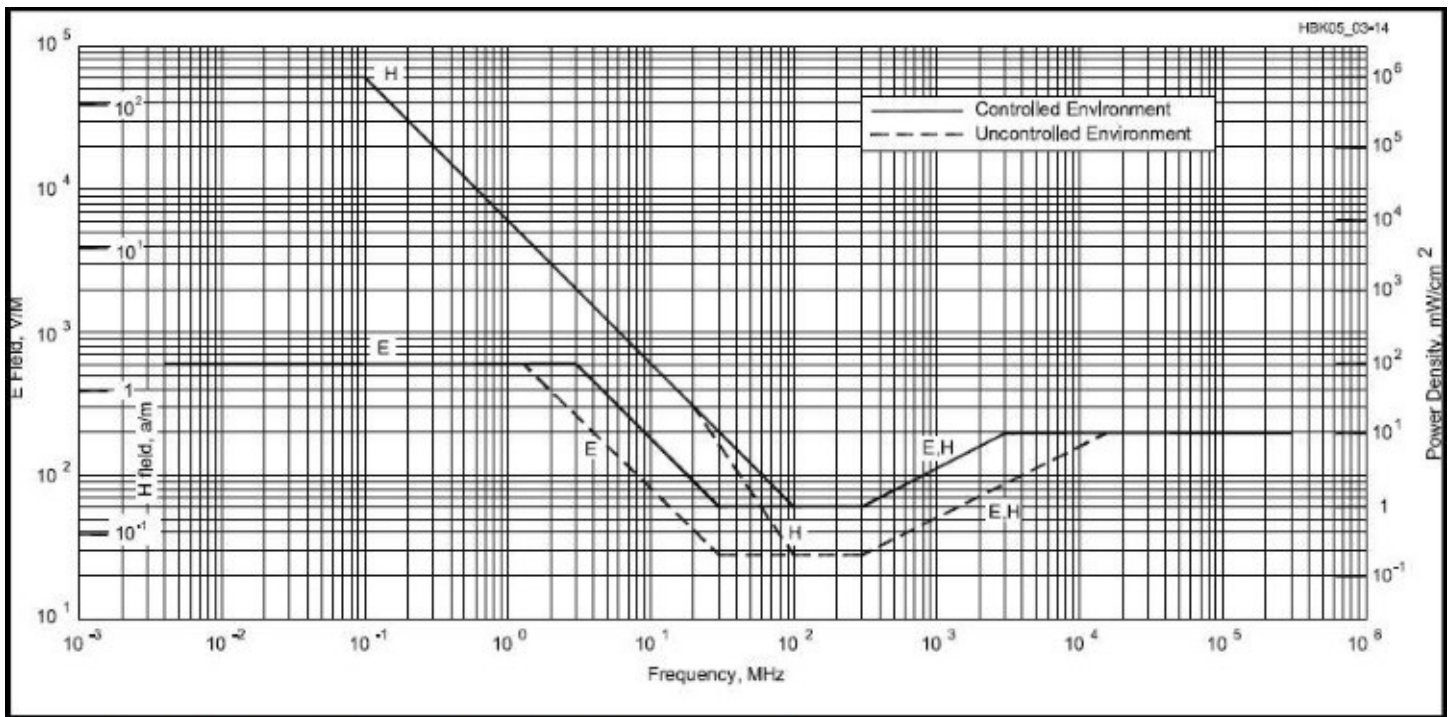

Figure 4.1 – 1991 RF protection guidelines for body exposure of humans.

In general, the ANSI/IEEE standard requires averaging the power level over time periods ranging from 6 to 30 minutes for power-density calculations, depending on the frequency and other variables. The ANSI/IEEE exposure limits for uncontrolled environments are lower than those for controlled environments, but to compensate for that, the standard allows exposure levels in those environments to be averaged over much longer time periods (generally 30 minutes). This long averaging time means that an intermittent RF source (such as an Amateur Radio transmitter) will result in a much lower exposure than a continuous-duty station, with all other parameters being equal. Time averaging is based on the concept that the human body can withstand a greater rate of body heating (and thus, a higher level of RF energy) for a short time.

Another national body in the United States, the National Council for Radiation Protection and Measurement (NCRP), has also adopted recommended exposure guidelines. NCRP urges a limit of  $0.2 \text{ mW/cm}^2$  for nonoccupational exposure in the 30-300 MHz range. The NCRP guideline differs from IEEE in that it takes into account the effects of modulation on an RF carrier.

The FCC MPE regulations are based on a combination of the 1992 ANSI/IEEE standard and 1986 NCRP recommendations. The MPE limits under the regulations are slightly different than the ANSI/IEEE limits and do not reflect all the assumptions and exclusions of the ANSI/IEEE standard.

## Cardiac Pacemakers and RF Safety

It is a widely held belief that cardiac pacemakers may be adversely affected in their function by exposure to electromagnetic fields. Amateurs with pacemakers may ask whether

their operating might endanger themselves or visitors to their shacks who have a pacemaker. Because of this, and similar concerns regarding other sources of EM fields, pacemaker manufacturers apply design methods that, for the most part, shield the pacemaker circuitry from even relatively high EM field strengths.

It is recommended that any amateur who has a pacemaker, or is being considered for one, discuss this matter with his or her physician. The physician will probably put the amateur into contact with the technical representative of the pacemaker manufacturer. These representatives are generally excellent resources, and may have data from laboratory or “in the field” studies with specific model pacemakers.

## **FCC RF Exposure Regulations**

FCC regulations control the amount of RF exposure that can result from your station’s operation (§§97.13, 97.503, 1.1307 (b)(c)(d), 1.1310, 2.1091 and 2.1093). The regulations set limits on the maximum permissible exposure (MPE) allowed from operation of transmitters in all radio services. They also require that certain types of stations be evaluated to determine if they are in compliance with the MPEs specified in the rules. The FCC has also required that questions on RF environmental safety practices be added to Technician and General license examinations.

### ***The Rules***

#### **Maximum Permissible Exposure (MPE)**

All radio stations regulated by the FCC must comply with the requirements for MPEs, even QRP stations running only a few watts or less. The MPEs vary with frequency, as shown in **Table A**. MPE limits are specified in maximum electric and magnetic fields for frequencies below 30 MHz, in power density for frequencies above 300 MHz and all three ways for frequencies from 30 to 300 MHz. For compliance purposes, all of these limits must be considered *separately*. If any one is exceeded, the station is not in compliance. In effect, this means that both electric and magnetic fields must be determined below 300 MHz, but at higher frequencies, determining either the electric or magnetic field is normally sufficient.

**Table A**  
**(From §1.1310) Limits for Maximum Permissible Exposure (MPE)**

**(A) Limits for Occupational/Controlled Exposure**

Frequency Range (MHz)	Electric Field Strength (V/m)	Magnetic Field Strength (A/m)	Power Density (mW/cm <sup>2</sup> )	Averaging Time (minutes)
0.3-3.0	614	1.63	(100)*	6
3.0-30	1842/f	4.89/f	(900/f <sup>2</sup> )*	6
30-300	61.4	0.163	1.0	6
300-1500	—	—	f/300	6
1500-100,000	—	—	5	6

f = Frequency in MHz

\* = Plane-wave equivalent power density (see Notes 1 and 2).

**(B) Limits for General Population/Uncontrolled Exposure**

Frequency Range (MHz)	Electric Field Strength (V/m)	Magnetic Field Strength (A/m)	Power Density (mW/cm <sup>2</sup> )	Averaging Time (minutes)
0.3-1.34	614	1.63	(100)*	30
1.34-30	824/f	2.19/f	(180/f <sup>2</sup> )*	30
30-300	27.5	0.073	0.2	30
300-1500	—	—	f/1500	30
1500-100,000	—	—	1.0	30

f = Frequency in MHz

\* = Plane-wave equivalent power density (see Notes 1 and 2).

Note 1: This means the equivalent far-field strength that would have the E- or H-field component calculated or measured. It does not apply well in the near field of an antenna. The equivalent far-field power density can be found in the near or far-field regions from the relationships:  $P_d = |E_{total}|^2 / 3770 \text{ mW/cm}^2$  or from  $P_d = |H_{total}|^2 \times 37.7 \text{ mW/cm}^2$ .

Note 2:  $|E_{total}|^2 = |E_x|^2 + |E_y|^2 + |E_z|^2$ , and  $|H_{total}|^2 = |H_x|^2 + |H_y|^2 + |H_z|^2$

The regulations control human exposure to RF fields, not the strength of RF fields in any space. There is no limit to how strong a field can be as long as no one is being exposed to it, although FCC regulations require that amateurs use the minimum necessary power at all times (§97.311 [a]).

**Environments**

The FCC has defined two tiers of exposure limits — *occupational/controlled limits and general population/uncontrolled limits*. Occupational/controlled limits apply when people are exposed as a condition of their employment and when they are aware of that exposure and can take steps to minimize it, if appropriate. General population/uncontrolled limits apply to exposure of the general public or people who are not normally aware of the exposure or cannot exercise control over it. The limits for general population/uncontrolled exposure are more stringent than the limits for occupational/controlled exposure. Specific definitions of the exposure categories can be found in Section 1.1310 of the FCC rules.

Although occupational/controlled limits are usually applicable in a workplace environment, the FCC has determined that they generally apply to amateur operators and members of their immediate households. In most cases, occupational/controlled limits can

be applied to your home and property to which you can control physical access. The general population/uncontrolled limits are intended for areas that are accessible by the general public, such as your neighbors' properties.

The MPE levels are based on average exposure. An averaging time of 6 minutes is used for occupational/controlled exposure; an averaging period of 30 minutes is used for general population/uncontrolled exposure.

### **Station Evaluations**

The FCC requires that certain amateur stations be evaluated for compliance with the MPEs. Although an amateur can have someone else do the evaluation, it is not difficult for hams to evaluate their own stations. The ARRL book *RF Exposure and You* contains extensive information about the regulations and a large chapter of tables that show compliance distances for specific antennas and power levels. Generally, hams will use these tables to evaluate their stations. Some of these tables have been included in the FCC's information — *OET Bulletin 65* and its *Supplement B* (available for downloading at the FCC's RF Safety website). If hams choose, however, they can do more extensive calculations, use a computer to model their antenna and exposure, or make actual measurements.

### **Categorical Exemptions**

Some types of amateur stations do not need to be evaluated, but these stations must still comply with the MPE limits. The station licensee remains responsible for ensuring that the station meets these requirements.

The FCC has exempted these stations from the evaluation requirement because their output power, operating mode and frequency are such that they are presumed to be in compliance with the rules.

Stations using power equal to, or less than, the levels in **Table B** do not have to be evaluated on a routine basis. For the 100 W HF ham station, for example, an evaluation would be required only on 12 and 10 meters.

Hand-held radios and vehicle-mounted mobile radios that operate using a push-to-talk (PTT) button are also categorically exempt from performing the routine evaluation.

Repeater stations that use less than 500 W ERP or those with antennas not mounted on buildings, if the antenna is at least 10 meters off the ground, also do not need to be evaluated.

### **Correcting Problems**

Most hams are already in compliance with the MPE requirements. Some amateurs, especially those using indoor antennas or high-power, high-duty-cycle modes such as a RTTY bulletin station and specialized stations for moonbounce operations and the like may need to make adjustments to their station or operation to be in compliance.

The FCC permits amateurs considerable flexibility in complying with these regulations. As an example, hams can adjust their operating frequency, mode or power to comply with

the MPE limits. They can also adjust their operating habits or control the direction their antenna is pointing.

---

**Table B**  
**Power Thresholds for Routine Evaluation**  
**of Amateur Radio Stations**

*Wavelength*                      *Evaluation Required if*  
*Band*                                      *Power\* (watts) Exceeds:*

**MF**

160 m                                      500

**HF**

80 m                                      500

75 m                                      500

40 m                                      500

30 m                                      425

20 m                                      225

17 m                                      125

15 m                                      100

12 m                                      75

10 m                                      50

**VHF (all bands)**    50

**UHF**

70 cm                                      70

33 cm                                      150

23 cm                                      200

13 cm                                      250

**SHF (all bands)**    250

**EHF (all bands)**    250

\*Transmitter power = Peak-envelope power  
input to antenna.

---

One study examined the function of a modern (dual chamber) pacemaker in and around an Amateur Radio station. The pacemaker generator has circuits that receive and process electrical signals produced by the heart, and also generate electrical signals that stimulate (pace) the heart. In one series of experiments, the pacemaker was connected to a heart simulator. The system was placed on top of the cabinet of a 1 kW HF linear amplifier during SSB and CW operation. In another test, the system was placed in proximity to several 1 to 5



W, 2-meter hand-held transceivers. The test pacemaker was connected to the heart simulator in a third test, and then placed on the ground 9 meters below and 5 meters in front of a three-element Yagi HF antenna. No interference with pacemaker function was observed in these experiments.

Although the possibility of interference cannot be entirely ruled out by these few observations, these tests represent more severe exposure to EM fields than would ordinarily be encountered by an amateur. Of course prudence dictates that amateurs with pacemakers, who use handheld VHF transceivers, keep the antenna as far as possible from the site of the implanted pacemaker generator. They also should use the lowest transmitter output required for adequate communication. For high-power HF transmission, the antenna should be as far as possible from the operating position, and all equipment should be properly grounded.

## **Low-Frequency Fields**

There has been considerable laboratory research about the biological effects of power-line RF. For example, some separate studies have indicated that even fairly low levels of RF exposure might alter the human body's circadian rhythms, affect the manner in which T lymphocytes function in the immune system and alter the nature of the electrical and chemical signals communicated through the cell membrane and between cells, among other things. Although these studies are intriguing, they do not demonstrate any effect of these low-level fields on the overall organism.

Much of this research has focused on low-frequency magnetic fields, or on RF fields that are keyed, pulsed or modulated at a low audio frequency (often below 100 Hz). Several studies suggested that humans and animals could adapt to the presence of a steady RF carrier more readily than to an intermittent, keyed or modulated energy source.

The results of studies in this area, plus speculations concerning the effect of various types of modulation, were and have remained somewhat controversial. None of the research to date has demonstrated that low-level RF causes adverse health effects.

Given the fact that there is a great deal of ongoing research to examine the health consequences of exposure to RF, the American Physical Society (a national group of highly respected scientists) issued a statement in May 1995 based on its review of available data pertaining to the possible connections of cancer to 60 Hz RF exposure. Their report is exhaustive and should be reviewed by anyone with a serious interest in the field. Among its general conclusions are the following:

1. The scientific literature and the reports of reviews by other panels show no consistent, significant link between cancer and power-line fields.
2. No plausible biophysical mechanisms for the systematic initiation or promotion of cancer by these extremely weak 60 Hz fields have been identified.
3. While it is impossible to prove that no deleterious health effects occur from exposure to any environmental factor, it is necessary to demonstrate a consistent, significant, and causal relationship before one can conclude that such effects do occur.

In a report dated October 31, 1996, a committee of the National Research Council of the National Academy of Sciences has concluded that no clear, convincing evidence exists to show that residential exposures to electric and magnetic fields (RF) are a threat to human health.

A National Cancer Institute epidemiological study of residential exposure to magnetic fields and acute lymphoblastic leukemia in children was published in the *New England Journal of Medicine* in July 1997. The exhaustive, seven-year study concludes that if there is any link at all, it is far too weak to be of concern.

In 1998, the US National Institute on Environmental Health Sciences organized a working group of experts to summarize the research on power-line RF. The committee used the classification rules of the International Agency for Research on Cancer (IARC) and performed a meta-analysis to combine all past results as if they had been performed in a single study. The NIEHS working group concluded that the research did not show this type of exposure to be a carcinogen but could not rule out the possibility either. Therefore, they defined power-line RF to be a Class 2b carcinogen under the IARC classification. The definition, as stated by the IARC, is: “Group 2B: The agent is possibly carcinogenic to humans. There is limited epidemiological evidence plus limited or inadequate animal evidence.” Other IARC Class 2b carcinogens include automobile exhaust, chloroform, coffee, ceramic and glass fibers, gasoline and pickled vegetables.

Amateurs should be aware that exposure to RF and ELF (60 Hz) electromagnetic fields at all power levels and frequencies has not been fully studied under all circumstances. “Prudent avoidance” of any avoidable RF is always a good idea. Prudent avoidance doesn’t mean that amateurs should be fearful of using their equipment. Most amateur operations are well within the MPE limits. If any risk does exist, it will almost surely fall well down on the list of causes that may be harmful to your health (on the other end of the list from your automobile). It does mean, however, that hams should be aware of the potential for exposure from their stations and take whatever reasonable steps they can take to minimize their own exposure and the exposure of those around them.

Although the FCC doesn’t regulate 60 Hz fields, some recent concern about RF has focused on 60 Hz. Amateur Radio equipment can be a significant source of 60 Hz fields, although there are many other sources of this kind of energy in the typical home. Magnetic fields can be measured relatively accurately with inexpensive 60 Hz meters that are made by several manufacturers.

**Table 4.1** shows typical magnetic field intensities of Amateur Radio equipment and various household items.

---

**Table 4.1****Typical 60-Hz Magnetic Fields Near Amateur Radio Equipment and AC-Powered Household Appliances**

Values are in milligauss.

<i>Item</i>	<i>Field</i>	<i>Distance</i>
Electric blanket	30-90	Surface
Microwave oven	10-100	Surface
	1-10	12 in.
Personal computer	5-10	Atop monitor
	0-1	15 in. from screen
Electric drill	500-2000	At handle
Hair dryer	200-2000	At handle
HF transceiver	10-100	Atop cabinet
	1-5	15 in. from front
1-kW RF amplifier	80-1000	Atop cabinet
	1-25	15 in. from front

(Source: measurements made by members of the ARRL RF Safety Committee)

---

## Determining RF Power Density

Unfortunately, determining the power density of the RF fields generated by an amateur station is not as simple as measuring low-frequency magnetic fields. Although sophisticated instruments can be used to measure RF power densities quite accurately, they are costly and require frequent recalibration. Most amateurs don't have access to such equipment, and the inexpensive field-strength meters that we do have are not suitable for measuring RF power density.

**Table 4.2** shows a sampling of measurements made at Amateur Radio stations by the Federal Communications Commission and the Environmental Protection Agency in 1990. As this table indicates, a good antenna well removed from inhabited areas poses no hazard under any of the ANSI/IEEE guidelines. However, the FCC/EPA survey also indicates that amateurs must be careful about using indoor or attic-mounted antennas, mobile antennas, low directional arrays or any other antenna that is close to inhabited areas, especially when moderate to high power is used.

---

**Table 4.2****Typical RF Field Strengths Near Amateur Radio Antennas**

A sampling of values as measured by the Federal Communications Commission and Environmental Protection Agency, 1990

<i>Antenna Type</i>	<i>Freq (MHz)</i>	<i>Power (W)</i>	<i>E Field (V/m)</i>	<i>Location</i>
Dipole in attic	14.15	100	7-100	In home
Discone in attic	146.5	250	10-27	In home
Half sloper	21.5	1000	50	1 m from base
Dipole at 7-13 ft	7.14	120	8-150	1-2 m from earth
Vertical	3.8	800	180	0.5 m from base
5-element Yagi at 60 ft	21.2	1000	10-20	In shack
			14	12 m from base
3-element Yagi at 25 ft	28.5	425	8-12	12 m from base
Inverted V at 22-46 ft	7.23	1400	5-27	Below antenna
Vertical on roof	14.11	140	6-9	In house
			35-100	At antenna tuner
Whip on auto roof	146.5	100	22-75	2-m antenna
			15-30	In vehicle
			90	Rear seat
5-element Yagi at 20 ft	50.1	500	37-50	10-m antenna

---

## So What About Your Indoor HF Station?

You'll find a handy RF safety calculator on the web at [http://hintlink.com/power\\_density.htm](http://hintlink.com/power_density.htm). However, before you can interpret the results, you'll need to determine if your antenna is in a "controlled" or "uncontrolled" environment.

An uncontrolled environment is one in which you have no control over who approaches your antenna. In fact, you may not even be aware that someone is near your antenna when you are transmitting. It is safe to say that an antenna in an apartment or condo building is going to have uncontrolled areas within just a few feet of the antenna.

### Fire and Burn Hazards

If you plan to run more than about 50 W output power, take care to keep your indoor antenna away from flammable materials. The ends of dipole antennas, for example, can develop high voltages at 50 or 100 W – enough to result in arcing that may spark a fire. Use insulators at the ends of your antenna wires and keep the ends about a foot from rafters, sheetrock walls, etc.

If your antenna is installed in an area where people might touch it, similar precautions apply. Let's say you have a miniature magnetic loop antenna in your living room. It should go without saying that you should not operate your station when anyone has even a remote chance of grabbing the loop. As in so many aspects of life, common sense should prevail!

Let's say that you install a wire dipole along the ceiling of your apartment. The apartment above yours is most definitely an uncontrolled environment, as are any apartments below yours, or to either side. In all likelihood, the closest anyone will be to your antenna in those uncontrolled environments will be two feet (the approximate thickness of the ceiling or walls).

Using the online calculator and assuming an operating frequency of 28.500 MHz, you'd have to lower your output power all the way down to 2 W to be in compliance with FCC regulations. This is a worst-case scenario because compliance is harder to obtain in uncontrolled environments at higher frequencies.

But let's try 20 meters instead. That's a popular band for indoor operating because a 20-meter dipole antenna can squeeze into an apartment with some creative arranging, as you saw in Chapter 2. According to the calculator, you'll be in compliance with those nearby uncontrolled environments at 10 W output. Ten watts on CW or digital is more than enough power to make plenty of contacts.

If you are fortunate enough to live in a detached home – one with neighbors farther away than the opposite side of the nearest wall – your permissible power levels rise considerably.

Imagine your indoor antenna in an attic and your neighbor's house at a distance of 30 feet. Running the 10-meter worse-case calculations again, we find that your station is compliant at 100 W output. In fact, you would be in compliance all the way to 500 W in that scenario.

Permissible limits in a controlled environment, one in which you are able to control who comes near your antenna, are generally much higher because the assumption is that you'll take care to keep others at a safe distance. Assuming the 10-meter operation with 100 W to an attic antenna in a detached house, your family members can come within about 8 feet of your antenna and still be within permissible RF levels.

Remember: you want to be prudent, not paranoid. While science has yet to make a strong association between RF energy and health risks, it is best to be conservative. On the other hand, don't allow unfounded fears to keep you from enjoying Amateur Radio.

Once you have your antenna installed, simply estimate the distance to the nearest uncontrolled environment for the band (or bands) on which you want to operate, and the power you wish to use, and then run the calculator. Do the same for the controlled environment (estimate the closest anyone, including you, will get to your antenna).

If necessary, reduce your RF output to the point where you achieve compliance for your highest frequency band of choice. Note the results of your calculations, file them away, and then have fun!

# No Outdoor Antenna? No Problem!



**If you're a ham who can't put up an outdoor antenna, this book is for you!**

Don't let outdoor antenna restrictions keep you from enjoying Amateur Radio. It is possible to operate on the HF bands with an antenna system that is entirely inside your house, apartment, or condominium. All it takes is some creative thinking!

**Ham Radio from Indoors** shows you how to install an effective indoor antenna system in any setting— even your living room. Getting the most out of your indoor station also means considering some different operating styles, such as HF digital. In **Ham Radio from Indoors** you'll find tips on maximizing your operating effectiveness, including CW shortcuts and a detailed tutorial about PSK31, one of the most popular HF digital modes for low power, indoor operating.

Interference and RF safety are among the top concerns for indoor operators. **Ham Radio from Indoors** offers advice to help you avoid interference problems, as well as a detailed discussion of RF safety.

## **Chapter 1—The Indoor Challenge**

Learn how to make the most of indoor operating with CW and digital modes.

## **Chapter 2—Indoor Antenna Designs**

From loops to dipoles, there is an indoor antenna that's guaranteed to work for you.

## **Chapter 3—Dealing with Interference**

When operating indoors, you're likely to be plagued with interference from your neighbors, and you may cause some interference yourself. This chapter offers concrete solutions.

## **Chapter 4—RF Safety**

You and your neighbors will be living in proximity to the RF you'll generate. There is no danger, but it never hurts to be cautious.



Published by:

**ARRL** The national association for  
**AMATEUR RADIO®**

225 Main Street, Newington, CT 06111-1494 USA

[www.arrl.org](http://www.arrl.org)